

International Astronomical Union

*Standards Of Fundamental Astronomy*

SOFA Tools for Earth Attitude

Software version 13  
Document revision 1.63

Version for Fortran programming language

<http://www.iausofa.org>

2020 December 14

MEMBERS OF THE IAU SOFA BOARD (2007)

John Bangert	United States Naval Observatory
Wim Brouw	University of Groningen
Mark Calabretta	Australia Telescope National Facility
Anne-Marie Gontier	Paris Observatory
Catherine Hohenkerk	Her Majesty's Nautical Almanac Office
Jin Wen-Jing	Shanghai Observatory
Zinovy Malkin	Inst. Appl. Astron., St Petersburg
Dennis McCarthy	United States Naval Observatory
Jeffrey Percival	University of Wisconsin
Patrick Wallace	Rutherford Appleton Laboratory

Past Members

George Kaplan	United States Naval Observatory
Skip Newhall	Jet Propulsion Laboratory

## Contents

<b>1</b>	<b>INTRODUCTION</b>	<b>1</b>
1.1	The SOFA software . . . . .	1
1.2	Quick start . . . . .	1
1.3	Abbreviations . . . . .	1
<b>2</b>	<b>CELESTIAL COORDINATES</b>	<b>3</b>
2.1	Stellar directions . . . . .	3
2.2	Precession-nutation . . . . .	3
2.3	Evolution of celestial reference systems . . . . .	4
2.4	The IAU 2000 changes . . . . .	7
2.5	Frame bias . . . . .	7
2.6	CIO and TIO . . . . .	8
2.7	Equation of the origins . . . . .	8
2.8	Equinox versus CIO . . . . .	8
2.9	The celestial to terrestrial transformation . . . . .	9
<b>3</b>	<b>SOFA EARTH ATTITUDE MODELS</b>	<b>10</b>
3.1	Classical precession . . . . .	10
3.2	Classical nutation . . . . .	11
3.3	The CIP $X, Y$ . . . . .	11
3.4	The CIO locator, $s$ . . . . .	12
3.5	Polar motion . . . . .	12
3.6	Earth rotation . . . . .	12
3.7	Fundamental arguments . . . . .	14
3.8	Supporting routines . . . . .	14
<b>4</b>	<b>CURRENT MODELS</b>	<b>15</b>
4.1	Canonical basis . . . . .	15
4.2	SOFAroutines . . . . .	16
<b>5</b>	<b>EXAMPLES</b>	<b>17</b>
5.1	Preliminaries . . . . .	18
5.2	IAU 1976/1980/1982/1994, equinox based . . . . .	19
5.3	IAU 2000A, CIO based, using classical angles . . . . .	21
5.4	IAU 2000A, equinox based, using classical angles . . . . .	22
5.5	IAU 2006/2000A, CIO based, using classical angles . . . . .	24
5.6	IAU 2006/2000A, CIO based, using $X, Y$ series . . . . .	25
<b>6</b>	<b>FURTHER READING</b>	<b>27</b>
<b>7</b>	<b>ROUTINE SPECIFICATIONS</b>	<b>29</b>
	iau_ANP . . . . .	29
	iau_BI00 . . . . .	30
	iau_BPN2XY . . . . .	31
	iau_C2I00A . . . . .	32
	iau_C2I00B . . . . .	34
	iau_C2IBPN . . . . .	36

iau_C2T00A	38
iau_C2T00B	40
iau_C2TEQX	42
iau_C2TPE	43
iau_C2TXY	45
iau_CAL2JD	47
iau_CR	48
iau_DAT	49
iau_EE00	51
iau_EE00A	52
iau_EE00B	53
iau_EE06A	54
iau_EECT00	55
iau_EO06A	57
iau_EORS	58
iau_EQEQ94	59
iau_ERA00	60
iau_FAD03	61
iau_FAE03	62
iau_FAF03	63
iau_FAJU03	64
iau_FAL03	65
iau_FALP03	66
iau_FAMA03	67
iau_FAME03	68
iau_FANE03	69
iau_FAOM03	70
iau_FAPA03	71
iau_FASA03	72
iau_FAUR03	73
iau_FAVE03	74
iau_FW2M	75
iau_FW2XY	77
iau_GMST00	78
iau_GMST06	79
iau_GMST82	80
iau_GST00A	81
iau_GST00B	82
iau_GST06	84
iau_GST06A	85
iau_GST94	86
iau_IR	87
iau_NUM00A	88
iau_NUM00B	89
iau_NUM06A	90
iau_NUMAT	91
iau_NUT00A	92
iau_NUT00B	95

iau_NUT06A . . . . .	97
iau_NUT80 . . . . .	99
iau_NUTM80 . . . . .	100
iau_OBL06 . . . . .	101
iau_OBL80 . . . . .	102
iau_P06E . . . . .	103
iau_PB06 . . . . .	105
iau_PFW06 . . . . .	106
iau_PMAT00 . . . . .	108
iau_PMAT06 . . . . .	109
iau_PMAT76 . . . . .	110
iau_PN00 . . . . .	111
iau_PN00A . . . . .	113
iau_PN00B . . . . .	115
iau_PN06 . . . . .	117
iau_PN06A . . . . .	119
iau_PNM00A . . . . .	121
iau_PNM00B . . . . .	122
iau_PNM06A . . . . .	123
iau_PNM80 . . . . .	124
iau_POM00 . . . . .	125
iau_PR00 . . . . .	126
iau_PREC76 . . . . .	128
iau_RX . . . . .	129
iau_RXP . . . . .	130
iau_RXR . . . . .	131
iau_RY . . . . .	132
iau_RZ . . . . .	133
iau_S00 . . . . .	134
iau_S00A . . . . .	136
iau_S00B . . . . .	137
iau_S06 . . . . .	138
iau_S06A . . . . .	140
iau_SP00 . . . . .	141
iau_TR . . . . .	142
iau_XY06 . . . . .	143
iau_XYS00A . . . . .	145
iau_XYS00B . . . . .	146
iau_XYS06A . . . . .	147



# 1 INTRODUCTION

## 1.1 The SOFA software

SOFA stands for *Standards Of Fundamental Astronomy*. The SOFA software is a collection of Fortran 77 and ANSI C subprograms that implement official IAU algorithms for fundamental-astronomy computations. At the present time the SOFA software comprises 189 astronomy routines supported by 55 utility (mainly vector/matrix) routines.

The basic documentation for the SOFA collection is terse, consisting of (i) detailed preamble comments in the individual routines and (ii) classified and alphabetic lists of the routine calls. For an important subset of the SOFA routines, namely those concerned with the Earth's orientation and rotation, the present document supplements the basic documentation with descriptive material and cookbook examples.

## 1.2 Quick start

Expert readers may wish to start with *Examples*, Section 5. Anyone already familiar with the elementary concepts can safely omit the introductory material in Section 2. Those interested in only the latest models can also omit Section 3, which has a large historical component, and start with *Current Models*, Section 4.

## 1.3 Abbreviations

BCRS	Barycentric Celestial Reference System
CIO	Celestial Intermediate Origin
CIP	Celestial Intermediate Pole
CIRS	Celestial Intermediate Reference System
EE	equation of the equinoxes
EMB	Earth-Moon barycenter
EO	equation of the origins
FK4	fourth fundamental catalog
FK5	fifth fundamental catalog
GCRS	Geocentric Celestial Reference System
GMST	Greenwich mean sidereal time
GST	Greenwich (apparent) sidereal time
IAU	International Astronomical Union
ICRS	International Celestial Reference System
IERS	International Earth rotation and reference systems service
ITRS	International Terrestrial Reference System
J2000.0	2000 January 1.5 (in some specified time scale)
NPB	nutatation, precession and frame bias
SOFA	Standards of Fundamental Astronomy
ST	sidereal time

TIO	Terrestrial Intermediate Origin
TIRS	Terrestrial Intermediate Reference System
TT	Terrestrial Time
UT	Universal Time UT1
UTC	Coordinated Universal Time
VLBI	very long baseline interferometry



## 2 CELESTIAL COORDINATES

### 2.1 Stellar directions

Specifying the geometric or apparent direction to a star (or some other body) involves a number of factors: what type of coordinates, the reference triad (the choice of pole and longitude zero), what sort of direction, where the observer is located. Key parts of the SOFA software concentrate on the first and second of these, providing definitive implementations of IAU models for precession-nutation and Earth rotation, supported by tools for manipulating spherical and vector coordinates. SOFA additionally provides a practical level of support for gravitational deflection, aberration, diurnal parallax, refraction and so on – see the *SOFA Astrometry Tools* cookbook.

SOFA’s transformation capabilities include not only the latest and most accurate methods but also a selection of former standards. Figures 1 and 2 show how some of the systems of celestial coordinates are related, to one another and to the direction in which a celestial source actually appears in the sky. Figure 1 is for the classical system of *mean places*, found in star catalogs and papers prior to the introduction of the International Celestial Reference System (ICRS); Figure 2 begins with ICRS coordinates and represents modern practices. At the bottom of each Figure is the *observed*  $[Az, El]$ , where a perfect theodolite would be pointed to see the source; and in the bodies of the two diagrams are the intermediate processing steps and coordinate systems.

To help understand these diagrams, and the supporting SOFA routines, we will review the coordinate systems involved, the astronomical phenomena that affect them and the different ways in which celestial coordinates can be managed.

### 2.2 Precession-nutation

We recall that the familiar *right ascension* and *declination*,  $[\alpha, \delta]$ , are the names of the longitude and latitude coordinates in a spherical polar system based on the Earth’s axis of rotation. The (classical) zero point of  $\alpha$  is the intersection of the *celestial equator* and the *ecliptic* (the apparent path of the Sun through the year) where the Sun moves into the northern hemisphere. This point is called the *first point of Aries*, or the *equinox*. This simple picture is complicated by the influence on the Earth’s orbit and orientation of the gravitational fields of the solar-system bodies: as a result of these influences neither the equator nor the ecliptic is fixed with respect to the distant background, and consequently a star’s  $[\alpha, \delta]$  coordinates are constantly changing.

The slow and large-scale effects are classically referred to as *precession*.

The phenomenon is further divided into *precession of the equator* and *precession of the ecliptic*, corresponding with the classical terms “luni-solar precession” which comes from the motion of the equator, and “planetary precession” which comes from the motion of the ecliptic.

The precession of the equator is caused by the torque exerted on the distorted and spinning Earth by tidal forces from the Moon (mainly) and Sun, with tiny additional contributions from

the planets. The result is that the Earth's rotation axis sweeps out a cone centered on the ecliptic pole, completing one revolution in about 26,000 years.

The precession of the ecliptic is caused by the influence on the Earth's orbital motion of the tidal forces from the planets. The effect is a slow (0".5 per year) secular rotation of the ecliptic about a slowly-moving diameter.

The ever-changing gravity gradient in which the Earth is immersed leads to a precessional motion that is itself constantly varying. However, the main 26,000-year component is on such a grand scale that it dwarfs the remaining terms, the biggest of which has an amplitude of only 11" and a period of about 18.6 years. This difference of scale makes it convenient to treat these two components of the motion separately, the smaller part being called *nutation*. Thus precession and nutation are simply different frequency components of a single physical phenomenon.

The models for precession-nutation come from a combination of observation and theory, and are subject to continuous refinement. In recent decades, nutation models in particular have become quite elaborate; the IAU 1980 nutation model provided by the SOFA routine `iau_NUT80` comprises only 106 terms in each of  $\psi$  (longitude) and  $\epsilon$  (obliquity), from 100  $\mu$ as upwards in amplitude whereas the IAU 2000A nutation model, implemented in the routine `iau_NUT00A`, requires 1365 terms, some as small as 0.1  $\mu$ as.

### 2.3 Evolution of celestial reference systems

Classical text-books use reference systems that are based on the celestial equator and the ecliptic, with the equinox as the zero point for right ascension. This simple geometrical picture is familiar, comfortable and works well for ordinary low-precision applications such as describing astronomical phenomena. However, when applied to more precise problems, complications arise. The Earth's pole (and hence equator) is in constant motion because of precession, nutation and polar motion; the ecliptic is a somewhat ill-defined concept and is itself constantly changing because of planetary perturbations. Using these moving planes in high-precision applications such as VLBI or pulsar timing became extremely complicated, and by the end of the 20th century the recommended procedures had changed:

1. The International Celestial Reference System was introduced, fixing the coordinate triad with reference to very distant objects. Although ICRS coordinates are close to FK5 J2000.0 mean places, this alignment was made merely for convenience, providing a degree of continuity. The ICRS is completely independent of the rotation and motion of the Earth: a given star has ICRS coordinates that are essentially fixed, changing only as a consequence of the star's own motion through space. In addition to the ICRS itself, new barycentric (BCRS) and geocentric (GCRS) celestial reference systems were introduced, to describe the relationship between different choices of space-time coordinates. These different systems are intimately related to the changing apparent direction of the light ray from the star as seen by different observers. As can be seen from Figure 2, BCRS coordinates apply to the star position once space motion has been taken into account; the apparent direction of the star as seen by a terrestrial observer is affected by parallax, light deflection by the Sun (and planets) and aberration, the result being expressed in GCRS coordinates. In effect, ICRS, BCRS and GCRS share the same orientation, and it is only once precession-nutation is considered that axes with a different orientation arise.

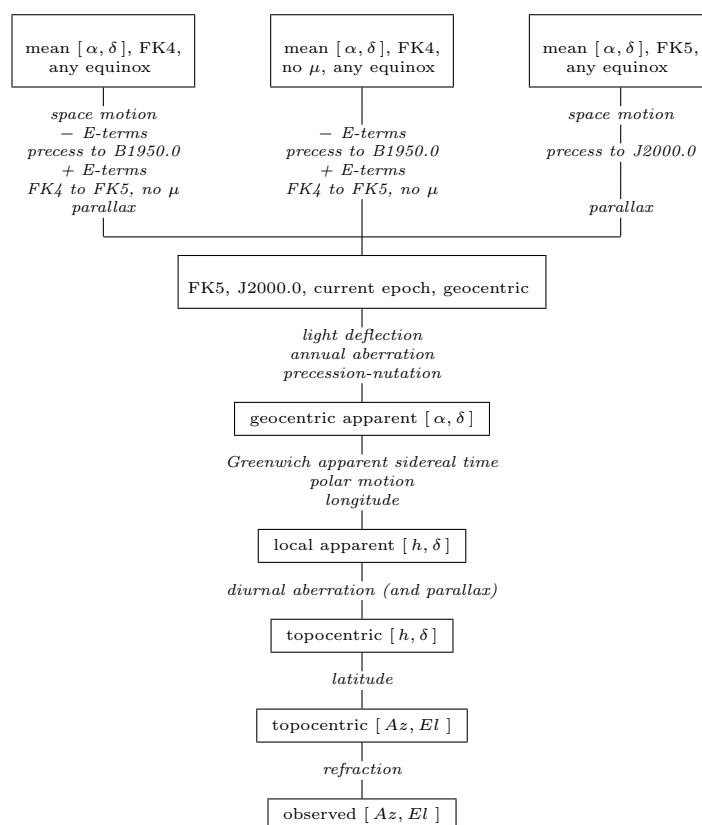

Figure 1: **Relationship between celestial coordinates, pre-ICRS**

Prior to the introduction of the International Celestial Reference System, star positions were published or cataloged using one of the mean  $[\alpha, \delta]$  systems shown at the top, each with its own specific precession and aberration models. The “FK4” systems, not at present supported by SOFA, were used before 1984 and were usually equinox B1950.0. The “FK5” system, equinox J2000.0 (to which the ICRS is nominally aligned), then took over. The figure relates a star’s mean  $[\alpha, \delta]$  to the actual line-of-sight to the star.

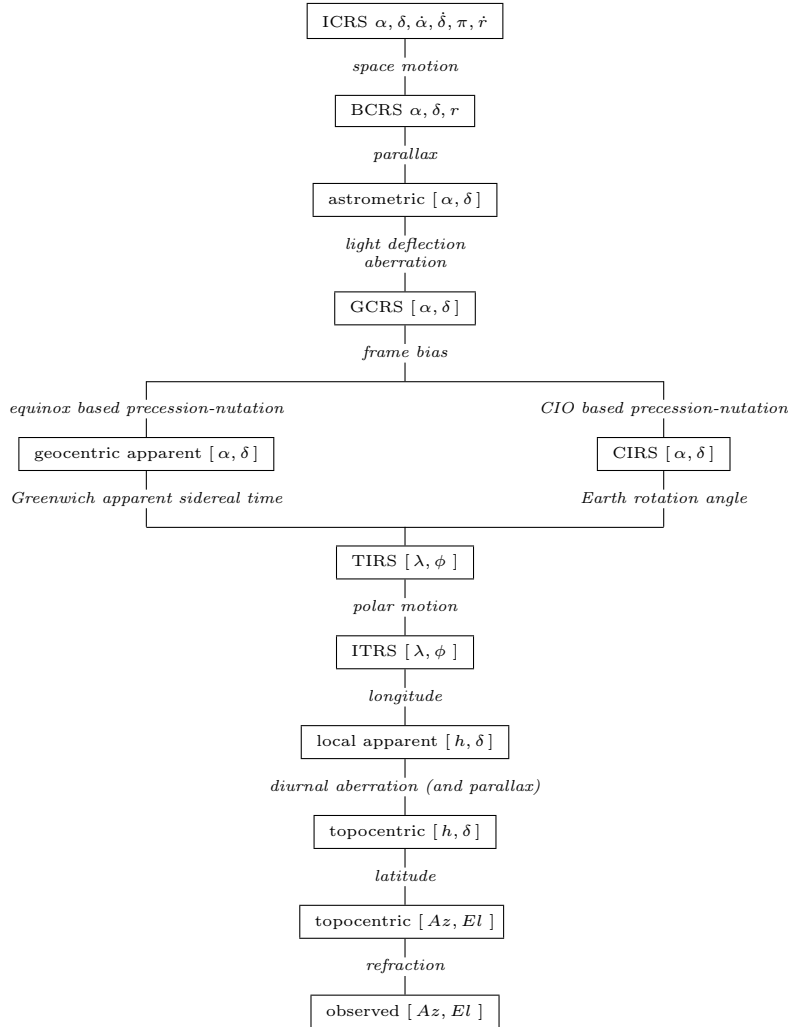

Figure 2: **Relationship between celestial coordinates, post-IAU-2000**

Since the introduction of the ICRS, the moving equator and ecliptic no longer provide the basis of high-precision astrometry, and mean places have fallen out of use. ICRS was nominally aligned to J2000.0 mean, with a residual *frame bias* of about 23 mas that can be ignored for many applications. In addition, a new zero-point for right ascension of date, the CIO, has replaced the equinox, breaking the final link with the ecliptic as far as the user is concerned. The figure relates a star's ICRS  $[\alpha, \delta]$  to the actual line-of-sight to the star. The right-hand branch shows the modern CIO/ERA method of reckoning the Earth rotation; the classical equinox/GST method, shown in the left-hand branch, remains an option for supporting older applications.

2. The ecliptic was retired as a reference plane for high-precision work. One difficulty had been a certain degree of confusion about exactly what “ecliptic” meant. Classically, the basis was the geometric path of the Sun as seen from the Earth-Moon barycenter, but it had become more usual instead to start from the EMB orbital angular momentum vector. It turns out these give the same result only if the orbital angular momentum vector is referred to the moving ecliptic itself; the angular momentum vector in inertial space leads to a slightly different plane, moving the equinox by about  $0''.1$ . Other difficulties with the ecliptic included exactly how to average out the orbital perturbations, uncertainty about whether the plane should go through the Sun or the solar-system barycenter, and so on.
3. Greenwich sidereal time (GST), which is a complicated function of both Earth rotation (UT1) and time (not quite the same thing), was replaced by *Earth rotation angle* (ERA), which is a straightforward linear transformation of UT1 alone and which represents the Earth’s rotation in inertial space.
4. The corollary of the change from GST to ERA is that the zero point of apparent right ascension has changed. The new  $\alpha$  zero-point is called the *celestial intermediate origin* (CIO). The CIO, a *non-rotating origin*, is kinematically, not geometrically, defined, with the result that it is impossible to draw a diagram that explains where the CIO is on a given date. However, the concept is easy to grasp: the CIO is simply a point on the equator that moves as little as possible. It necessarily bobs north and south as the equator of date moves, but does not move along the equator; from moment to moment its motion is always at right-angles to the equator. For epoch 2000.0 the CIO was placed close to GCRS right ascension zero, and throughout the 20th and 21st centuries it remains within  $0''.1$  of that alignment.

## 2.4 The IAU 2000 changes

The switch from equinox/GST to CIO/ERA, introduced by the IAU in 2000 in order to bring about a clean separation between Earth rotation and precession-nutation, will take some years to come into wide use. Although recent textbooks have embraced the ICRS, all but a handful pre-date the introduction of the CIO, making it difficult to teach the new methods – even though they are in many ways simpler, with less to go wrong. There is in any case little incentive now that astronomers no longer need to prepare apparent places for their observing runs, a chore left to the telescope control computer. Furthermore, the latest and most precise precession-nutation and Earth rotation theories can be presented using either framework, with equal accuracy and with hardly any difference in the total amount of computation required. Given these factors, and taking into account the large number of equinox/GST based applications that exist, the SOFA policy at present is to support both methods – with the strong recommendation that for all new applications the CIO based methods should be adopted.

## 2.5 Frame bias

The International Celestial Reference System was nominally oriented to match the J2000.0 dynamical frame. Subsequent observations located the J2000.0 mean pole at ICRS  $[X, Y]$

coordinates  $[-0^{\circ}016617, -0^{\circ}0068192]^1$ , with the J2000.0 mean equinox lying  $0^{\circ}0146$  west of the ICRS meridian.

## 2.6 CIO and TIO

The celestial intermediate origin, CIO, is located using a quantity called  $s(t)$ , which is the difference between two right ascensions of the same point. The point is the ascending node of the (moving) CIP equator on the (fixed) GCRS equator; the two right ascensions are with respect to the GCRS and the CIP/CIO respectively. The quantity  $s$  is defined by an integral that depends on the path of the precessing-nutating CIP, but is normally estimated using a series. The series used in the SOFA routines `iau_S00` and `iau_S06` is in fact for  $s + XY/2$ , where  $X$  and  $Y$  are the CIP coordinates of date.

There is an analogous quantity  $s'$  that applies to terrestrial coordinates, depends on the history of polar motion, and locates the terrestrial intermediate origin, TIO. It is extremely small, under 0.1 mas even after two centuries. The SOFA routine `iau_SP00` implements a standard model.

## 2.7 Equation of the origins

The *equation of the origins* (EO) is a useful quantity that captures the essential difference between the old and the new systems. In applications that need to support both the old, equinox based, and new, CIO based, systems, it will usually be found best to base the application on CIO/ERA and to use the EO when dealing with sidereal time and equinox based right ascensions.

The expression for calculating hour angle is the same in either the old or new system:

$$h = \theta - \alpha,$$

where  $\theta$  is now Earth rotation angle but was formerly Greenwich apparent sidereal time, and  $\alpha$  is referred to the celestial intermediate origin but was formerly referred to the true equinox of date. The difference ERA–GST, or equivalently the distance from the equinox to the CIO, is called the “equation of the origins” (EO). The EO is dominated by the precession in right ascension, causing it to change by about  $46''$  per year, but includes also the nutation in right ascension (otherwise known as the equation of the equinoxes) and a number of small correction terms.

## 2.8 Equinox versus CIO

Although in the classical picture precession-nutation is thought of as affecting both the equator and the equinox, the latter aspect is nothing more than a geometrical consequence of the chosen coordinate system. The essence of precession-nutation is that it is all about the motion of the Earth’s pole (and hence the equator), and in the post-IAU-2000 CIO based approach it is both

---

<sup>1</sup>When components of a unit vector are quoted in angular measure this should be taken to mean the radian equivalent.

normal and sufficient to specify the instantaneous pole, which is called the *celestial intermediate pole* (CIP), simply as  $[X, Y]$ , the first two components of the CIP's GCRS unit vector. Indeed, one attraction of the new method is that series for  $X(t)$  and  $Y(t)$  exist (see the SOFA routine `iau_XY06`) that deliver the CIP as a function of time in a particularly straightforward way.

Even so, the ecliptic is never far away. The tidal forces that cause precession-nutation are from bodies that remain near the ecliptic plane, and descriptions of these effects are at their most concise when expressed in ecliptic based coordinates. Hence even in the latest precession theories there is still an ecliptic, and the existing nutation series are with respect to the mean equator and ecliptic of date.

Moreover, the classical precession angles, when used to generate the  $3 \times 3$  precession matrix, automatically deliver the equinox, whether it is wanted or not. It appears as the top row of the epoch-to-date precession-nutation matrix, which is the unit vector towards the equinox (just as the bottom row is the unit vector towards the pole; the middle row is simply the vector product pole  $\times$  equinox).

On the face of it, this makes direct use of the classical matrix attractive. Starting with existing precession and nutation models, it delivers traditional equinox based right ascensions without further ado, ready to be used in conjunction with sidereal time. However, there is a hidden danger. Any change in the precession or nutation models requires a corresponding change to the formulation of sidereal time, and it is the SOFA user's responsibility to employ a matching set of precession, nutation and sidereal time models if hour angles are to be calculated reliably. For example, mixing old and new precession-nutation and sidereal time can introduce errors in  $h$  at the  $0''.05$  level.

In the newer SOFA routines, multiple sidereal time formulations are avoided by working internally with respect to the CIO, which is nearly independent of the adopted precession-nutation model. The distance between the CIO and the chosen equinox is the *equation of the origins* (see Section 2.7). The EO can be calculated from any supplied precession-nutation matrix, and if subtracted from the Earth rotation angle automatically yields a Greenwich apparent sidereal time appropriate for use with that particular matrix.

## 2.9 The celestial to terrestrial transformation

Figure 2 shows how frame bias, precession-nutation, Earth rotation and polar motion form a chain of transformations connecting celestial coordinates (GCRS) to terrestrial coordinates (ITRS). Written out in matrix form, the chain is:

$$\mathbf{v}_{\text{ITRS}} = \mathbf{R}_{\text{PM}} \times \mathbf{R}_3(\theta) \times \mathbf{R}_{\text{NPB}} \times \mathbf{v}_{\text{GCRS}} \quad (1)$$

where:

- $\mathbf{v}_{\text{GCRS}}$  and  $\mathbf{v}_{\text{ITRS}}$  are the same direction with respect to the two reference systems;
- the matrix  $\mathbf{R}_{\text{NPB}}$  represents the combined effects of frame bias and precession-nutation and defines the orientation of the celestial intermediate pole and a longitude origin;

- $\mathbf{R}_3(\theta)$  is Earth rotation, with  $\theta$  either ERA or GST depending on whether  $\mathbf{R}_{\text{NPB}}$  is CIO based or equinox based; and
- the matrix  $\mathbf{R}_{\text{PM}}$  takes account of polar motion.

The sequence of coordinate systems in Eq. (1) is:

1. The Geocentric Celestial Reference System, which is effectively the same orientation as ICRS. The bias+precession+nutration transformation then produces...
2. ...either Celestial Intermediate Reference System coordinates, if the matrix  $\mathbf{R}_{\text{NPB}}$  was CIO based, or classical apparent place, if the matrix  $\mathbf{R}_{\text{NPB}}$  was equinox based. The rotation through either ERA or GST, as appropriate, then gives...
3. ...Terrestrial Intermediate Reference System coordinates, which after polar motion has been applied and the small adjustment onto the terrestrial intermediate origin (TIO) has been made gives...
4. ...International Terrestrial Reference System coordinates: where on the Earth the star appears to be in the (geographical) zenith, and easily transformed into  $[h, \delta]$  for other locations.

## 3 SOFA EARTH ATTITUDE MODELS

### 3.1 Classical precession

For equinox based use, SOFA offers a choice of three models for the classical precession:

- The Fricke-Lieske, IAU 1976, “FK5” model. The conventional  $\zeta$ ,  $z$  and  $\theta$  Euler angles are generated by the SOFA routine `iau_PREC76` and the precession matrix by `iau_PMAT76`.
- The IAU 2000 model. This is in the form of corrections, due to Mathews, Herring & Buffet, to the IAU 1976 model. The corrections can be obtained by calling `iau_PR00` (rates) and `iau_BI00` (position, i.e. frame bias). The complete precession matrix, including frame bias, is available from `iau_PMAT00`, while individual frame bias and precession matrices can be obtained with `iau_BP00`.
- The Capitaine et al. IAU 2006 model. The SOFA routine `iau_PFW06` produces the four Fukushima-Williams angles,  $\bar{\gamma}$ ,  $\bar{\phi}$ ,  $\bar{\psi}$  and  $\epsilon_A$ , that automatically include the frame bias. The precession+bias matrix is available from `iau_PMAT06`. Another advantage of the Fukushima-Williams parameterization is that the classical nutation angles  $\Delta\psi$  and  $\Delta\epsilon$  can be added directly to the final two angles,  $\bar{\psi}$  and  $\epsilon_A$ , if the desired end product is the complete nutation+precession+bias matrix.

Another aspect of precession is the obliquity of the ecliptic. There are two supported models:

- The IAU 1976 mean obliquity, which can be computed by calling `iau_OBL80`. This obliquity also forms the foundation for the IAU 2000A/B precession-nutation.
- The IAU 2006 mean obliquity, `iau_OBL06`.



### 3.2 Classical nutation

SOFA provides three nutation models:

- The IAU 1980 model: `iau_NUT80`.
- The IAU 2000A model: `iau_NUT00A`.
- The IAU 2000B model: `iau_NUT00B`.

All three return the classical components of nutation in longitude and obliquity,  $\Delta\psi$ ,  $\Delta\epsilon$ , from which a nutation matrix can (if required) be generated by calling `iau_NUMAT`, and from which the *equation of the equinoxes* (EE), described later, can be found.

The IAU 2000B model is an abridged version of the full 1365-frequency IAU 2000A model. It is a fraction of the size (smaller even than the IAU 1980 model) and achieves 1 mas accuracy throughout 1995-2050.

The best nutation model that is currently available is IAU 2000A. When using this in conjunction with the latest (IAU 2006) precession model it is formally necessary to apply certain small adjustments to the nutation. This IAU-2006-compatible form of the IAU 2000A nutation is available from the routine `iau_NUT06A`. When using the IAU 2000B nutation these adjustments can be neglected.

If the application requires the nutation in the classical matrix form, it can be generated in a single call by using `iau_NUTM80`, `iau_NUM00A`, `iau_NUM00B` or `iau_NUM06A` for the IAU 1980, IAU 2000A, IAU 2000B or IAU 2006/2000A variants respectively.

### 3.3 The CIP $X, Y$

SOFA offers six routines for obtaining  $X, Y$ , the first two coordinates of the CIP unit vector:

- When the bias-precession-nutation matrix is already known, the CIP  $X, Y$  can be extracted by calling `iau_BPN2XY`.
- The IAU 2000A  $X, Y$ , together with the CIO locator  $s$ , can be obtained using `iau_XYS00A`.
- For the IAU 2000B model,  $X, Y$  and  $s$  can be obtained by calling `iau_XYS00B`.
- When the bias-precession-nutation is available in the form of Fukushima-Williams angles, the CIP coordinates can be computed with `iau_FW2XY`.
- In the case of the IAU 2006/2000A model, SOFA provides a routine `iau_XY06` that computes  $X$  and  $Y$  directly from series. This formulation is distinct from the other SOFA IAU 2006/2000A routines but agrees at the 1  $\mu$ as level.

### 3.4 The CIO locator, $s$

Although direct series for  $s$  exist, a more concise result is obtained if the quantity modeled is not  $s$  itself but  $s + XY/2$ , where  $X, Y$  are the CIP coordinates. SOFA provides three routines for  $s$  in the IAU 2000 system...

- The routine `iau_S00A` calculates  $s$ , first evaluating the IAU 2000A bias-precession-nutation to obtain the CIP coordinates  $X$  and  $Y$ .
- The routine `iau_S00B` does the same but using the IAU 2000B model.
- Where  $X$  and  $Y$  are already known, it is computationally more efficient to call the routine `iau_S00`.

... and two routines for  $s$  in the IAU 2006/2000A system:

- The routine `iau_S06A` calculates  $s$ , first evaluating the IAU 2006/2000A bias-precession-nutation to obtain the CIP coordinates  $X$  and  $Y$ .
- Where  $X$  and  $Y$  are already known (for example from `iau_XY06`), it is computationally more efficient to call the routine `iau_S06`.

### 3.5 Polar motion

The polar motion matrix,  $\mathbf{R}_{PM}$  in Eq. (1) depends on IERS tabulations of the pole coordinates  $x_p, y_p$ . The SOFA routine `iau_POM00` uses these pole coordinates, together with the TIO locator  $s'$  to construct the  $\mathbf{R}_{PM}$  matrix. A conventional estimate of  $s'$  is provided by the routine `iau_SP00`. Prior to the introduction of the IAU 2000 procedures  $s'$  was neglected.

### 3.6 Earth rotation

In Eq. 1, the angle  $\theta$  is either Greenwich apparent sidereal time (if  $\mathbf{R}_{NPB}$  is equinox based) or Earth rotation angle (if  $\mathbf{R}_{NPB}$  is CIO based). SOFA includes routines to calculate both.

Support for classical sidereal time accounts for a total of 14 SOFA routines. The large number is because:

- Sidereal time includes a precession-nutation component as well as the main Earth rotation component. Consequently, each new precession-nutation model requires its own matching sidereal time model.

- Sidereal time has several component parts. The ST that is  $\theta$  in the expression:

$$h_{\text{Greenwich}} = \theta - \alpha_{\text{apparent}}$$

is *apparent* sidereal time and comprises:

$$\theta = \text{GMST} + \text{EE}$$

where EE is the *equation of the equinoxes*. The classical equation of the equinoxes is  $\Delta\psi \cos \epsilon$ , where  $\Delta\psi$  is the nutation in longitude and  $\epsilon$  is the obliquity, but from 1994 small periodic corrections called the *complementary terms* have been added.

SOFA provides three generations of IAU GMST models:

- `iau_GMST82` computes the IAU 1982 GMST, consistent with the IAU 1976 precession.
- `iau_GMST00` computes the GMST consistent with the precession part of IAU 2000A.
- `iau_GMST06` computes the GMST consistent with the IAU 2006 precession.

Five SOFA routines deliver the equation of the equinoxes:

- `iau_EQEQ94` computes the IAU 1994 EE.
- `iau_EE00A` computes the IAU 2000A EE.
- `iau_EE00B` computes the IAU 2000B EE.
- Where  $\Delta\psi$  and  $\epsilon$  are already available, `iau_EE00` can be called, producing the IAU 2000 EE.
- `iau_EE06A` computes the IAU 2006/2000A EE.

The SOFA routine `iau_EECT00` computes the value of the EE complementary terms for the IAU 2000 case. No corresponding IAU 2000/2000A routine exists; should the quantity be needed, it can be computed by subtracting  $\Delta\psi \cos \epsilon$  from the EE, the latter obtained by calling `iau_EE06A`.

Finally, SOFA routines are provided for calculating five generations of Greenwich apparent sidereal time:

- `iau_GST94` computes the IAU 1994 GST.
- `iau_GST00A` computes the IAU 2000A GST.
- `iau_GST00B` computes the IAU 2000B GST.
- `iau_GST06` computes the GST starting from the NPB matrix. Although the routine uses the IAU 2006/2000A series for  $s + XY/2$  (hence its “06” suffix), it is otherwise independent of the precession-nutation model and can in practice be used with any equinox based NPB matrix.

- `iau_GST06A` computes the IAU 2006/2000A GST.

Working with respect to the CIO rather than the equinox sweeps away sidereal time's complexities and opportunities for error. The Earth rotation angle, the CIO based counterpart of GST, is simply a conventional linear transformation of UT1, and only one SOFA routine is needed:

- `iau_ERA00`: Earth rotation angle.

### 3.7 Fundamental arguments

The models for nutation, the CIO locator  $s$  and the CIP  $X, Y$  are all functions of *fundamental arguments*, angles which themselves are functions of time. SOFA routines implement the IERS 2003 expressions for 14 such angles:

<code>iau_FAL03</code>	Delaunay variable $l$
<code>iau_FALP03</code>	Delaunay variable $l'$
<code>iau_FAF03</code>	Delaunay variable $F$
<code>iau_FAD03</code>	Delaunay variable $D$
<code>iau_FA0M03</code>	Delaunay variable $\Omega$
<code>iau_FAME03</code>	mean longitude of Mercury
<code>iau_FAVE03</code>	mean longitude of Venus
<code>iau_FAE03</code>	mean longitude of Earth
<code>iau_FAMA03</code>	mean longitude of Mars
<code>iau_FAJU03</code>	mean longitude of Jupiter
<code>iau_FASA03</code>	mean longitude of Saturn
<code>iau_FAUR03</code>	mean longitude of Uranus
<code>iau_FANE03</code>	mean longitude of Neptune
<code>iau_FAPA03</code>	general accumulated precession in longitude

In a few cases the published models use slightly different expressions for one or two of the fundamental arguments, and where this occurs the SOFA routine uses the published expression rather than the standard version.

### 3.8 Supporting routines

The successive generations of precession-nutation models are supported by SOFA routines that generate the various matrices from a variety of starting points.

The IAU 1976/1980 models are used by `iau_PNM80`.

The IAU 2000A/B models are used by `iau_C2I00A`, `iau_C2I00B`, `iau_C2IBPN`, `iau_C2T00A`, `iau_C2T00B`, `iau_C2TPE`, `iau_C2TXY`, `iau_PN00`, `iau_PN00A`, `iau_PN00B`, `iau_PNM00A` and `iau_PNM00B`.

SOFA support for the current generation of models, based on the IAU 2006/2000A precession-nutation, is described in more detail in the next Section.

## 4 CURRENT MODELS

The latest models supported by SOFA are based on the IAU 2006 precession, the IERS 2003 polar motion and the IAU 2000 nutation and Earth rotation. With one exception (`iau_XY06`), all the SOFA routines rest upon a non-redundant set of models, guaranteeing self consistency: the same quantity computed via different sequences of SOFA calls should not vary apart from rounding errors.

### 4.1 Canonical basis

The models that form the *primary canonical basis* for the latest SOFA routines, supporting both CIO based and equinox based applications, are as follows:

- The IAU 2006 precession model, in the Fukushima-Williams four angle parameterization.
- The IAU 2000A nutation model.
- The IAU 2006 adjustments to the IAU 2000A nutation model.
- The IAU 2006 model for the quantity  $s + XY/2$ , which locates the celestial intermediate origin on the CIP equator.
- The IAU 2000 model for the quantity  $s'$ , which locates the terrestrial intermediate origin on the CIP equator.
- The IAU 2000 expression for ERA(UT1).
- A GMST model consistent with IAU 2006.

The derived products are:

- Precession-nutation matrices, for transforming between GCRS and apparent place (either CIO based or equinox based).
- CIP coordinates  $X, Y$ .
- Equation of the origins,  $EO = ERA - GST$ .
- Greenwich (apparent) sidereal time, GST.
- Equation of the equinoxes,  $EE = GST - GMST$ .

An alternative canonical basis for the CIO based products is:

- Direct series for the IAU 2006/2000A CIP  $X, Y$ .
- The IAU 2006/2000A model for  $s + XY/2$ .

- The IAU 2000 model for  $s'$ .
- The IAU 2000 expression for ERA(UT1).

To support equinox based applications the following additional models are required:

- The first two Fukushima-Williams angles, namely  $\bar{\gamma}$  and  $\bar{\phi}$ .
- A GMST model consistent with IAU 2006.

The angles based and series based approaches agree to of order  $1 \mu\text{as}$ ; anyone attempting to mix the two techniques in a single application should not be surprised when discrepancies of this size appear. See Wallace, P.T. & Capitaine, N., *Precession-nutation procedures consistent with IAU 2006 resolutions*, *Astronomy & Astrophysics*, **459**, 981-985, 2006 for further details of the two methods.

## 4.2 SOFARoutines

With the exception of `iau_XY06`, which computes CIP  $X, Y$  directly by series, and `iau_P06E`, which calculates all the equinox based IAU 2006 precession angles, all of the SOFA routines whose names contain “06” stem from the primary canonical basis set out at the start of Section 4. Hence the remainder of the present Section applies to the primary canonical basis rather than the alternative  $X, Y$  series starting point. Also, with the partial exception of the low-level routines `iau_PN06`, `iau_PN06A` and `iau_BP06`, which keep frame bias and precession separate, everything refers to the GCRS pole rather than the dynamical pole.

For any given date, the complete matrix  $\mathbf{R}_{\text{NPB}}$  in Eq. (1) can be obtained by calling the routine `iau_C2I06A`, for the CIO based version, or `iau_PNM06A`, for the equinox based version.

At a lower level, the routine `iau_PFW06` returns the Fukushima-Williams precession angles themselves (with frame bias included), while `iau_NUT06A` obtains the nutation components. Once these nutation components have been added to the appropriate two precession angles, the equinox based  $\mathbf{R}_{\text{NPB}}$  matrix can be generated by calling `iau_FW2M`. Alternatively, the CIP  $X, Y$  coordinates can be obtained by calling `iau_FW2XY`, the CIO locator  $s$  computed using the routine `iau_S06A`, and the CIO based  $\mathbf{R}_{\text{NPB}}$  matrix formed using `iau_C2IXYS`. This latter route provides an opportunity to introduce corrections to  $X, Y$ , as published by the IERS. The resulting matrix transforms from GCRS to CIRS; its transpose, available by calling `iau_TR`, performs the inverse transformation, i.e. CIRS to GCRS.

To support older applications that use the Euler angles  $\zeta, z, \theta$  to construct the precession matrix, the routine `iau_PB06` is provided. The starting point is the Fukushima-Williams angles, so that the  $\zeta, z, \theta$  returned by `iau_PB06` are consistent with the primary canonical basis, and include frame bias.

Earth rotation angle, from which  $\mathbf{R}_3(\theta)$  in the CIO based form of Expression (1) can be applied, is available using `iau_ERA00`, which is a function of UT1 alone. Or, for the case where the

equinox based form of Expression (1) is being used, the requisite Greenwich apparent sidereal time can be obtained by calling `iau_GST06A`, a function of time (*i.e.* TT) as well as UT1.

A rotation matrix that performs the complete celestial to terrestrial transformation (i.e. GCRS to ITRS), given the TT, UT1 and polar motion, can be obtained by calling `iau_C2T06A`. Low-level routines `iau_C2TCIO` and `iau_C2TEQX` (which are in fact identical in form) construct the GCRS to ITRS matrix given an appropriate NPB matrix, a polar motion matrix, and the ERA or GST.

A key component of the GST calculation is the equation of the origins, which can be obtained as a function of time by calling `iau_E006A`. Alternatively, to obtain the EO corresponding to an independently calculated  $\mathbf{R}_{\text{NPB}}$  matrix and CIO locator, `iau_EORS` can be called. As well as its role in computing GST, the EO is useful when CIRS right ascension is to be computed from apparent right ascension or *vice versa*. Should the application require GMST or EE, the former can be computed by calling `iau_GMST06` and the latter by subtracting GMST from GST.

Section 5.5 demonstrates how to generate the CIO based celestial to terrestrial transformation with the usual angles based method. Section 5.6 does the same but starting from the  $X, Y$  series. In both cases IERS CIP corrections and Earth orientation parameters are taken into account.

## 5 EXAMPLES

Sections 5.1–5.6, below, present a complete Fortran program that computes the GCRS-to-ITRS transformation matrix and various intermediate products, using a number of different approaches and generations of SOFA routines. The code is interspersed with explanatory text and numerical results, but is otherwise compilable as it stands.

Five methods are demonstrated:

- 5.2 IAU 1976/1980/1982/1994 (equinox based)
- 5.3 IAU 2000A, CIO based, using classical angles
- 5.4 IAU 2000A, equinox based, using classical angles
- 5.5 IAU 2006/2000A, CIO based, using classical angles
- 5.6 IAU 2006/2000A, CIO based, using  $X, Y$  series

The starting point is as follows:

date & time	2007 April 05, 12 <sup>h</sup> 00 <sup>m</sup> 00 <sup>s</sup> .0 UTC
$x_p$	+0 <sup>o</sup> .0349282
$y_p$	+0 <sup>o</sup> .4833163
UT1–UTC	–0 <sup>s</sup> .072073685
$d\psi_{1980}$	–0 <sup>o</sup> .0550655
$d\epsilon_{1980}$	–0 <sup>o</sup> .0063580

$dX_{2000}$	+0"0001725
$dY_{2000}$	-0"0002650
$dX_{2006}$	+0"0001750
$dY_{2006}$	-0"0002259

The Earth orientation parameters, which are available from the IERS, are corrections to the standard Earth models and come from observation: the polar motion quantities  $x_p$  and  $y_p$  correct the terrestrial pole, UT1–UTC is the time correction that defines the Earth rotation, and  $dX_{2000}$  and  $dY_{2000}$  are corrections to the celestial pole with respect to the IAU 2000A model. (n.b. **The above values are purely for illustration** but in fact are fairly close to those for the given date.)

The quantities  $dX_{2006}$  and  $dY_{2006}$  are adjusted versions of  $dX_{2000}$  and  $dY_{2000}$  that **for the purposes of this demonstration** correct the celestial pole with respect to the IAU 2006/2000A model.<sup>2</sup>

## 5.1 Preliminaries

The program begins as follows:

---

```

* SOFA examples

    IMPLICIT NONE

* Arcseconds to radians
    DOUBLE PRECISION AS2R
    PARAMETER ( AS2R = 4.848136811095359935899141D-6 )

    INTEGER IY, IM, ID, IH, MIN, J
    DOUBLE PRECISION SEC, XP, YP, DUT1,
:           DDP80, DDE80, DX00, DY00, DX06, DY06,
:           UTC1, UTC2, TAI1, TAI2, TT1, TT2, UT11, UT12,
:           RP(3,3), DP80, DE80,
:           DPSI, DEPS, EPSA, RN(3,3), RNPB(3,3),
:           EE, GST, RC2TI(3,3), RPOM(3,3),
:           RC2IT(3,3), X, Y, S,
:           RC2I(3,3), ERA, SP, DP00, DE00, RB(3,3),
:           RPB(3,3), V1(3), V2(3), DDP00, DDE00
    DOUBLE PRECISION iau_OBL80, iau_EQEQ94, iau_ANP, iau_GMST82,
:           iau_ERA00, iau_SP00, iau_EE00, iau_GMST00,
:           iau_S06

```

---

<sup>2</sup>The adjustments were computed by calling `iau_XYS00A` and `iau_XYS06A` for the given date and subtracting the respective  $X, Y$  coordinates.



```

* UTC.
  IY = 2007
  IM = 4
  ID = 5
  IH = 12
  MIN = 0
  SEC = 0D0

* Polar motion (arcsec->radians).
  XP = 0.0349282D0 * AS2R
  YP = 0.4833163D0 * AS2R

* UT1-UTC (s).
  DUT1 = -0.072073685D0

* Nutation corrections wrt IAU 1976/1980 (mas->radians).
  DDP80 = -55.0655D0 * AS2R/1000D0
  DDE80 = -6.3580D0 * AS2R/1000D0

* CIP offsets wrt IAU 2000A (mas->radians).
  DX00 = 0.1725D0 * AS2R/1000D0
  DY00 = -0.2650D0 * AS2R/1000D0

* CIP offsets wrt IAU 2006/2000A (mas->radians).
  DX06 = 0.1750D0 * AS2R/1000D0
  DY06 = -0.2259D0 * AS2R/1000D0

* From UTC get TT and UT1.
  CALL iau_DTF2D ( 'UTC', IY, IM, ID, IH, MIN, SEC, UTC1, UTC2, J )
  CALL iau_UTCTAI ( UTC1, UTC2, TAI1, TAI2, J )
  CALL iau_TAI TT ( TAI1, TAI2, TT1, TT2, J )
  CALL iau_UTCUT1 ( UTC1, UTC2, DUT1, UT11, UT12, J )

```

---

The resulting TT and UT1 are as follows:

```

TT   = 2454195.5 + 0.5007544444444444
UT1  = 2454195.5 + 0.499999165813831

```

n.b. Here and elsewhere the numerical results are given to an unrealistic precision, for comparison purposes.

## 5.2 IAU 1976/1980/1982/1994, equinox based

The next part of the Fortran code demonstrates the procedures that were used prior to the introduction (at the beginning of 2003) of the methods specified in the IAU 2000 resolutions.

---

```

* =====
* IAU 1976/1980
* =====

* IAU 1976 precession matrix, J2000.0 to date.
  CALL iau_PMAT76 ( TT1, TT2, RP )

* IAU 1980 nutation.
  CALL iau_NUT80 ( TT1, TT2, DP80, DE80 )

* Add adjustments: frame bias, precession-rates, geophysical.
  DPSI = DP80 + DDP80
  DEPS = DE80 + DDE80

* Mean obliquity.
  EPSA = iau_OBL80 ( TT1, TT2 )

* Build the rotation matrix.
  CALL iau_NUMAT ( EPSA, DPSI, DEPS, RN )

* Combine the matrices: PN = N x P.
  CALL iau_RXR ( RN, RP, RNPB )

* Equation of the equinoxes, including nutation correction.
  EE = iau_EQEQ94 ( TT1, TT2 ) + DDP80 * COS(EPSA)

* Greenwich apparent sidereal time (IAU 1982/1994).
  GST = iau_ANP ( iau_GMST82 ( UT11, UT12 ) + EE )

* Form celestial-terrestrial matrix (no polar motion yet).
  CALL iau_CR ( RNPB, RC2TI )
  CALL iau_RZ ( GST, RC2TI )

* Polar motion matrix (TIRS->ITRS, IERS 1996).
  CALL iau_IR ( RPOM )
  CALL iau_RX ( -YP, RPOM )
  CALL iau_RY ( -XP, RPOM )

* Form celestial-terrestrial matrix (including polar motion).
  CALL iau_RXR ( RPOM, RC2TI, RC2IT )

```

---

The results are as follows:

NPB matrix, equinox based

$$\begin{pmatrix} +0.999998403176203 & -0.001639032970562 & -0.000712190961847 \\ +0.001639000942243 & +0.999998655799521 & -0.000045552846624 \\ +0.000712264667137 & +0.000044385492226 & +0.999999745354454 \end{pmatrix}$$

$$\begin{aligned} \text{GST} &= 13^{\circ}412402380740 \\ &= 00^{\text{h}} 53^{\text{m}} 38^{\text{s}}976571378 \end{aligned}$$

celestial to terrestrial matrix (no polar motion)

$$\begin{pmatrix} +0.973104317592265 & +0.230363826166883 & -0.000703332813776 \\ -0.230363798723533 & +0.973104570754697 & +0.000120888299841 \\ +0.000712264667137 & +0.000044385492226 & +0.999999745354454 \end{pmatrix}$$

celestial to terrestrial matrix

$$\begin{pmatrix} +0.973104317712772 & +0.230363826174782 & -0.000703163477127 \\ -0.230363800391868 & +0.973104570648022 & +0.000118545116892 \\ +0.000711560100206 & +0.000046626645796 & +0.999999745754058 \end{pmatrix}$$

### 5.3 IAU 2000A, CIO based, using classical angles

At the start of 2003, the IAU 2000A precession-nutation model came into use. The following code uses classical precession and nutation angles to obtain the CIP coordinates  $X, Y$ , then uses the CIO locator  $s$  and the Earth rotation angle.

---

```

* =====
* IAU 2000A, CIO based
* =====

* CIP and CIO, IAU 2000A.
  CALL iau_XYS00A ( TT1, TT2, X, Y, S )

* Add CIP corrections.
  X = X + DX00
  Y = Y + DY00

* GCRS to CIRS matrix.
  CALL iau_C2IXYS ( X, Y, S, RC2I )

* Earth rotation angle.
  ERA = iau_ERA00 ( UT11, UT12 )

* Form celestial-terrestrial matrix (no polar motion yet).
  CALL iau_CR ( RC2I, RC2TI )
  CALL iau_RZ ( ERA, RC2TI )

```

```

* Polar motion matrix (TIRS->ITRS, IERS 2003).
  CALL iau_POM00 ( XP, YP, iau_SPO0(TT1,TT2), RPOM )

* Form celestial-terrestrial matrix (including polar motion).
  CALL iau_RXR ( RPOM, RC2TI, RC2IT )

```

---

The results are as follows:

```

X   = +0.000712264729708
Y   = +0.000044385250265
s   = -0o.002200496

```

NPB matrix, CIO based

$$\begin{pmatrix} +0.999999746339445 & -0.000000005138721 & -0.000712264730182 \\ -0.000000026475329 & +0.99999999014975 & -0.000044385242666 \\ +0.000712264729708 & +0.000044385250265 & +0.999999745354420 \end{pmatrix}$$

```

ERA = 13o318492966097
     = 00h 53m 16s.438311863

```

celestial to terrestrial matrix (no polar motion)

$$\begin{pmatrix} +0.973104317573104 & +0.230363826247808 & -0.000703332818915 \\ -0.230363798804281 & +0.973104570735550 & +0.000120888549767 \\ +0.000712264729708 & +0.000044385250265 & +0.999999745354420 \end{pmatrix}$$

celestial to terrestrial matrix

$$\begin{pmatrix} +0.973104317697512 & +0.230363826239227 & -0.000703163482268 \\ -0.230363800456136 & +0.973104570632777 & +0.000118545366806 \\ +0.000711560162777 & +0.000046626403835 & +0.999999745754024 \end{pmatrix}$$

The rotational difference between the final matrices of this and the previous method is 53.29  $\mu$ as.

#### 5.4 IAU 2000A, equinox based, using classical angles

Equinox based applications could instead do the following. In this case the nutation corrections ( $d\psi, d\epsilon$ ) must be obtained by appropriately transforming the CIP corrections ( $dX, dY$ ). It is necessary to select the GMST and EE routines that match the IAU 2000A precession, in this case `iau_GMST00` and `iau_EE00`.

---

```

* =====
* IAU 2000A, equinox based
* =====

* Nutation, IAU 2000A.
  CALL iau_NUT00A ( TT1, TT2, DPO0, DE00 )

* Precession-nutation quantities, IAU 2000.
  CALL iau_PN00 ( TT1, TT2, DPO0, DE00,
:               EPSA, RB, RP, RPB, RN, RNPB )

* Transform dX,dY corrections from GCRS to mean of date.
  V1(1) = DX00
  V1(2) = DY00
  V1(3) = ODO
  CALL iau_RXP ( RNPB, V1, V2 )
  DDP00 = V2(1) / SIN(EPSA)
  DDE00 = V2(2)

* Corrected nutation.
  DPSI = DPO0 + DDP00
  DEPS = DE00 + DDE00

* Build the rotation matrix.
  CALL iau_NUMAT ( EPSA, DPSI, DEPS, RN )

* Combine the matrices: PN = N x P.
  CALL iau_RXR ( RN, RPB, RNPB )

* Greenwich apparent sidereal time (IAU 2000).
  GST = iau_ANP ( iau_GMST00 ( UT11, UT12, TT1, TT2 )
:               + iau_EE00 ( TT1, TT2, EPSA, DPSI ) )

* Form celestial-terrestrial matrix (no polar motion yet).
  CALL iau_CR ( RNPB, RC2TI )
  CALL iau_RZ ( GST, RC2TI )

* Polar motion matrix (TIRS->ITRS, IERS 2003).
  SP = iau_SPO0 ( TT1, TT2 )
  CALL iau_POM00 ( XP, YP, SP, RPOM )

* Form celestial-terrestrial matrix (including polar motion).
  CALL iau_RXR ( RPOM, RC2TI, RC2IT )

```

---

The results are as follows:

NPB matrix, equinox based

$$\begin{pmatrix} +0.999998402755640 & -0.001639289519579 & -0.000712191013215 \\ +0.001639257491365 & +0.999998655379006 & -0.000045552787478 \\ +0.000712264729795 & +0.000044385250265 & +0.999999745354420 \end{pmatrix}$$

$$\begin{aligned} \text{GST} &= 13^{\circ}412417084674 \\ &= 00^{\text{h}} 53^{\text{m}} 38^{\text{s}}980100322 \end{aligned}$$

celestial to terrestrial matrix (no polar motion)

$$\begin{pmatrix} +0.973104317573209 & +0.230363826247361 & -0.000703332818999 \\ -0.230363798803834 & +0.973104570735656 & +0.000120888549787 \\ +0.000712264729795 & +0.000044385250265 & +0.999999745354420 \end{pmatrix}$$

celestial to terrestrial matrix

$$\begin{pmatrix} +0.973104317697618 & +0.230363826238780 & -0.000703163482352 \\ -0.230363800455689 & +0.973104570632883 & +0.000118545366826 \\ +0.000711560162864 & +0.000046626403835 & +0.999999745754024 \end{pmatrix}$$

The rotational difference between the final matrices of this and the previous method (5.3) is  $0.10 \mu\text{as}$ .

## 5.5 IAU 2006/2000A, CIO based, using classical angles

From the beginning of 2009 the IAU 2006 precession will be used. The procedure based on classical precession and nutation angles is essentially the same as before (see Section 5.3), the only change being to call `iau_XYS06A` instead of `iau_XYS00A`.

---

```

* =====
* IAU 2006/2000A, CIO based
* =====

* CIP and CIO, IAU 2006/2000A.
  CALL iau_XYS06A ( TT1, TT2, X, Y, S )

* Add CIP corrections.
  X = X + DX06
  Y = Y + DY06

* GCRS to CIRS matrix.
  CALL iau_C2IXYS ( X, Y, S, RC2I )

```

```

* Earth rotation angle.
  ERA = iau_ERA00 ( UT11, UT12 )

* Form celestial-terrestrial matrix (no polar motion yet).
  CALL iau_CR ( RC2I, RC2TI )
  CALL iau_RZ ( ERA, RC2TI )

* Polar motion matrix (TIRS->ITRS, IERS 2003).
  SP = iau_SPO0 ( TT1, TT2 )
  CALL iau_POM00 ( XP, YP, SP, RPOM )

* Form celestial-terrestrial matrix (including polar motion).
  CALL iau_RXR ( RPOM, RC2TI, RC2IT )

```

---

The results are as follows:

```

X   = +0.000712264729599
Y   = +0.000044385250426
s   = -0o.002200475

```

NPB matrix, CIO based

$$\begin{pmatrix} +0.999999746339445 & -0.000000005138822 & -0.000712264730072 \\ -0.000000026475227 & +0.99999999014975 & -0.000044385242827 \\ +0.000712264729599 & +0.000044385250426 & +0.999999745354420 \end{pmatrix}$$

```

ERA = 13o318492966097
     = 00h 53m 16s.438311863

```

celestial to terrestrial matrix (no polar motion)

$$\begin{pmatrix} +0.973104317573127 & +0.230363826247709 & -0.000703332818845 \\ -0.230363798804182 & +0.973104570735574 & +0.000120888549586 \\ +0.000712264729599 & +0.000044385250426 & +0.999999745354420 \end{pmatrix}$$

celestial to terrestrial matrix

$$\begin{pmatrix} +0.973104317697535 & +0.230363826239128 & -0.000703163482198 \\ -0.230363800456037 & +0.973104570632801 & +0.000118545366625 \\ +0.000711560162668 & +0.000046626403995 & +0.999999745754024 \end{pmatrix}$$

The rotational difference between the final matrices of this and method (5.3) is 0.05  $\mu$ as.

## 5.6 IAU 2006/2000A, CIO based, using X,Y series

SOFA also provides an alternative formulation for the IAU 2006/2000A CIP, using series:

---

```

* =====
* IAU 2006/2000A, CIO based, using X,Y series
* =====

* CIP and CIO, IAU 2006/2000A.
  CALL iau_XY06 ( TT1, TT2, X, Y )
  S = iau_S06 ( TT1, TT2, X, Y )

* Add CIP corrections.
  X = X + DX06
  Y = Y + DY06

* GCRS to CIRS matrix.
  CALL iau_C2IXYS ( X, Y, S, RC2I )

* Earth rotation angle.
  ERA = iau_ERA00 ( UT11, UT12 )

* Form celestial-terrestrial matrix (no polar motion yet).
  CALL iau_CR ( RC2I, RC2TI )
  CALL iau_RZ ( ERA, RC2TI )

* Polar motion matrix (TIRS->ITRS, IERS 2003).
  SP = iau_SP00 ( TT1, TT2 )
  CALL iau_POM00 ( XP, YP, SP, RPOM )

* Form celestial-terrestrial matrix (including polar motion).
  CALL iau_RXR ( RPOM, RC2TI, RC2IT )

  END

```

---

The results are as follows:

```

X   = +0.000712264729525
Y   = +0.000044385248875
s   = -0"002200475

```

NPB matrix, CIO based

$$\begin{pmatrix} +0.999999746339445 & -0.000000005138822 & -0.000712264729999 \\ -0.000000026475226 & +0.999999999014975 & -0.000044385241276 \\ +0.000712264729525 & +0.000044385248875 & +0.999999745354420 \end{pmatrix}$$

```

ERA = 13°318492966097

```



$$= 00^{\text{h}} 53^{\text{m}} 16^{\text{s}}.438311863$$

celestial to terrestrial matrix (no polar motion)

$$\begin{pmatrix} +0.973104317573127 & +0.230363826247709 & -0.000703332818416 \\ -0.230363798804181 & +0.973104570735574 & +0.000120888551078 \\ +0.000712264729525 & +0.000044385248875 & +0.999999745354420 \end{pmatrix}$$

celestial to terrestrial matrix

$$\begin{pmatrix} +0.973104317697536 & +0.230363826239128 & -0.000703163481769 \\ -0.230363800456036 & +0.973104570632801 & +0.000118545368117 \\ +0.000711560162594 & +0.000046626402444 & +0.999999745754024 \end{pmatrix}$$

The rotational difference between the final matrices of this and method (5.3) is  $0.29 \mu\text{as}$ .

## 6 FURTHER READING

For numerical examples, with explanatory material, see *The Astronomical Almanac* and similar national publications. An extensive glossary is available as part of *The Astronomical Almanac Online*: see <http://asa.hmnao.com/SecM/Glossary.html>.

Detailed information on models and procedures can be found in:

- *Precession-nutation procedures consistent with IAU 2006 resolutions*, P. T. Wallace & N. Capitaine, *Astronomy & Astrophysics*, 459, 981-985 (2006)
- *High precision methods for locating the celestial intermediate pole and origin*, N. Capitaine & P. T. Wallace, *Astronomy & Astrophysics*, 450, 855-872 (2006)
- *Report of the International Astronomical Union Division I Working Group on Precession and the Ecliptic*, J. L. Hilton, N. Capitaine, J. Chapront, et al. *Celestial Mechanics & Dynamical Astronomy*, 94, 3, 351-367 (2006)
- *The IAU Resolutions on Astronomical Reference Systems, Time Scales, and Earth Rotation Models: Explanation and Implementation*, G. H. Kaplan, U.S. Naval Observatory Circular 179 (2005)  
[http://aa.usno.navy.mil/publications/docs/Circular\\_179.html](http://aa.usno.navy.mil/publications/docs/Circular_179.html)
- *IERS Conventions (2003)*, D. D. McCarthy & G. Petit (eds.), Verlag des Bundesamts für Kartographie und Geodäsie, Frankfurt am Main (2004)
- *Expressions for IAU 2000 precession quantities*, N. Capitaine, P. T. Wallace & J. Chapront, *Astronomy & Astrophysics*, 412, 567-586 (2003)
- *A new precession formula*, T. Fukushima, *Astronomical Journal*, 126, 1, 494-534 (2003)

- *An abridged model of the precession-nutation of the celestial pole*, D.D. McCarthy & B. J. Luzum, *Celestial Mechanics & Dynamical Astronomy*, 85, 1, 37-49 (2003)
- *Modeling of nutation and precession: new nutation series for non-rigid Earth and insights into the Earth's interior*, P. M. Mathews, T. A. Herring & B. A. Buffet, *Journal of Geophysical Research*, 107, B4, ETG 3:1-26 (2002)
- *Application of the new concepts and definitions (ICRS, CIP and CEO) in fundamental astronomy*, P. K. Seidelmann & J. Kovalevsky, *Astronomy & Astrophysics*, 392, 341-351 (2002)
- *Definition of the Celestial Ephemeris Origin and of UT1 in the International Celestial Reference Frame*, N. Capitaine, B. Guinot & D. D. McCarthy, *Astronomy & Astrophysics*, 355, 398-405 (2000)
- *The celestial pole coordinates*, N. Capitaine, *Celestial Mechanics & Dynamical Astronomy*, 48, 2, 127-143 (1990)
- *1980 IAU theory of nutation – the final report of the IAU Working Group on Nutation*, P. K. Seidelmann, *Celestial Mechanics*, 27, 79-106 (1982)
- *The new definition of Universal Time*, S. Aoki, B. Guinot, G. H. Kaplan, et al., *Astronomy & Astrophysics*, 105, 359-361 (1982)
- *Expressions for the precession quantities based upon the IAU (1976) system of astronomical constants*, J. H. Lieske, T. Lederle, W. Fricke & B. Morando, *Astronomy & Astrophysics*, 58, 1, 1-16 (1977)

The following may also be useful for background reading:

- *Explanatory Supplement to the Astronomical Almanac*, ed. Sean E. Urban & P. Kenneth Seidelmann, 3rd Edition (2013), University Science Books
- *Vectorial Astrometry*, C. A. Murray (1983), Adam Hilger
- *Spherical Astronomy*, Robin M. Green (1985), Cambridge University Press
- *Spacecraft Attitude Determination and Control*, ed. James R. Wertz (1986), Reidel
- *Fundamentals of Astrometry*, J. Kovalevsky & P. K. Seidelmann, Cambridge University Press

## 7 ROUTINE SPECIFICATIONS

The following pages present in alphabetical order details of all the SOFA routines referred to in the present document. These are mainly concerned with the Earth's orientation and rotation, but for convenience a few other routines that happen to be used in the code examples are included as well.

---

<b>iau_ANP</b>	<i>normalize radians to range 0 to 2<math>\pi</math></i>	<b>iau_ANP</b>
----------------	--	----------------

**CALL :**

D = iau\_ANP ( A )

**ACTION :**

Normalize angle into the range  $0 \leq A < 2\pi$ .

**GIVEN :**

<i>A</i>	d	angle (radians)
----------	---	-----------------

**RETURNED** (function value) :

d	angle in range 0-2 $\pi$
---	--------------------------

---

<b>iau_BI00</b>	<i>frame bias, IAU 2000</i>	<b>iau_BI00</b>
-----------------	-----------------------------	-----------------

**CALL :**

CALL iau\_BI00 ( DPSIBI, DEPSBI, DRA )

**ACTION :**

Frame bias components of IAU 2000 precession-nutation models; part of the Mathews-Herring-Buffett (MHB2000) nutation series, with additions.

**RETURNED :**

<i>DPSIBI</i>	d		longitude correction (radians)
<i>DEPSBI</i>	d		obliquity correction (radians)
<i>DRA</i>	d		the ICRS RA of the J2000.0 mean equinox (radians)

**NOTES :**

1. The frame bias corrections in longitude and obliquity (radians) are required in order to correct for the offset between the GCRS pole and the J2000.0 mean pole. They define, with respect to the GCRS frame, a J2000.0 mean pole that is consistent with the rest of the IAU 2000A precession-nutation model.
2. In addition to the displacement of the pole, the complete description of the frame bias requires also an offset in right ascension. This is not part of the IAU 2000A model, and is from Chapront et al. (2002). It is returned in radians.
3. This is a supplemented implementation of one aspect of the IAU 2000A nutation model, formally adopted by the IAU General Assembly in 2000, namely MHB2000 (Mathews et al. 2002).

**REFERENCES :**

1. Chapront, J., Chapront-Touzé, M. & Francou, G., 2002, *Astron.Astrophys.*, **387**, 700.
2. Mathews, P.M., Herring, T.A., Buffet, B.A., 2002, *J.Geophys.Res.*, **107**, B4. The MHB2000 code itself was obtained on 2002 September 9 from <ftp://maia.usno.navy.mil/conv2000/chapter5/IAU2000A>.

---

**iau\_BPN2XY**      *extract CIP X,Y from BPN matrix*      **iau\_BPN2XY**

**CALL :**

CALL iau\_BPN2XY ( RBPN, X, Y )

**ACTION :**

Extract from the bias-precession-nutation matrix the  $X, Y$  coordinates of the Celestial Intermediate Pole.

**GIVEN :**

*RBPN*      d(3,3)      celestial-to-true matrix (Note 1)

**RETURNED :**

$X, Y$       d      Celestial Intermediate Pole (Note 2)

**NOTES :**

1. The matrix *RBPN* transforms vectors from GCRS to true equator (and CIO or equinox) of date, and therefore the Celestial Intermediate Pole unit vector is the bottom row of the matrix.
2.  $X, Y$  are components of the Celestial Intermediate Pole unit vector in the Geocentric Celestial Reference System.

**REFERENCE :**

Capitaine, N., Chapront, J., Lambert, S. and Wallace, P., 2003, *Astron.Astrophys.* **400**, 1145-1154.

---

**iau\_C2I00A**      *celestial-to-intermediate matrix, IAU 2000A*      **iau\_C2I00A**

**CALL :**

CALL iau\_C2I00A ( DATE1, DATE2, RC2I )

**ACTION :**

Form the celestial-to-intermediate matrix for a given date using the IAU 2000A precession-nutation model.

**GIVEN :**

*DATE1*      d                      TT as a two-part...  
*DATE2*      d                      ... Julian Date (Note 1)

**RETURNED :**

*RC2I*        d(3,3)                      celestial-to-intermediate matrix (Note 2)

**NOTES :**

1. The TT date  $DATE1+DATE2$  is a Julian Date, apportioned in any convenient way between the arguments  $DATE1$  and  $DATE2$ . For example,  $JD(TT) = 2450123.7$  could be expressed in any of these ways, among others:

DATE1	DATE2	
2450123.7D0	0D0	(JD method)
2451545.0D0	-1421.3D0	(J2000 method)
2400000.5D0	50123.2D0	(MJD method)
2450123.5D0	0.2D0	(date & time method)

The JD method is the most natural and convenient to use in cases where the loss of several decimal digits of resolution is acceptable. The J2000 method is best matched to the way the argument is handled internally and will deliver the optimum resolution. The MJD method and the date & time methods are both good compromises between resolution and convenience.

2. The matrix  $RC2I$  is the first stage in the transformation from celestial to terrestrial coordinates:

$$\begin{aligned} \mathbf{v}_{TRS} &= \mathbf{R}_{POM} \mathbf{R}_3(ERA) \mathbf{R}_{C2I} \mathbf{v}_{CRS} \\ &\equiv \mathbf{R}_{C2T} \mathbf{v}_{CRS} \end{aligned}$$

where  $\mathbf{v}_{TRS}$  is a vector in the International Terrestrial Reference System (see IERS Conventions 2003),  $\mathbf{R}_{POM}$  is the polar motion matrix,  $ERA$  is the Earth Rotation Angle,  $\mathbf{R}_{C2I}$  is the matrix  $RC2I$  returned by the present routine, and  $\mathbf{v}_{CRS}$  is a vector in the Geocentric Celestial Reference System.

3. A faster, but slightly less accurate, result (about 1 mas) can be obtained by using instead the `iau_C2I00B` routine.

**REFERENCES :**

1. Capitaine, N., Chapront, J., Lambert, S. & Wallace, P., 2003, *Astron.Astrophys.* **400**, 1145-1154.
2. McCarthy, D.D., Petit, G. (eds.), 2004, *IERS Conventions (2003)*, IERS Technical Note No. 32, BKG.

---

**iau\_C2I00B**      *celestial-to-intermediate matrix, IAU 2000B*      **iau\_C2I00B**

**CALL :**

CALL iau\_C2I00B ( DATE1, DATE2, RC2I )

**ACTION :**

Form the celestial-to-intermediate matrix for a given date using the IAU 2000B precession-nutation model.

**GIVEN :**

*DATE1*      d                      TT as a two-part...  
*DATE2*      d                      ... Julian Date (Note 1)

**RETURNED :**

*RC2I*        d(3,3)                      celestial-to-intermediate matrix (Note 2)

**NOTES :**

1. The TT date  $DATE1+DATE2$  is a Julian Date, apportioned in any convenient way between the arguments  $DATE1$  and  $DATE2$ . For example,  $JD(TT) = 2450123.7$  could be expressed in any of these ways, among others:

DATE1	DATE2	
2450123.7D0	0D0	(JD method)
2451545.0D0	-1421.3D0	(J2000 method)
2400000.5D0	50123.2D0	(MJD method)
2450123.5D0	0.2D0	(date & time method)

The JD method is the most natural and convenient to use in cases where the loss of several decimal digits of resolution is acceptable. The J2000 method is best matched to the way the argument is handled internally and will deliver the optimum resolution. The MJD method and the date & time methods are both good compromises between resolution and convenience.

2. The matrix  $RC2I$  is the first stage in the transformation from celestial to terrestrial coordinates:

$$\begin{aligned} \mathbf{v}_{TRS} &= \mathbf{R}_{POM} \mathbf{R}_3(ERA) \mathbf{R}_{C2I} \mathbf{v}_{CRS} \\ &\equiv \mathbf{R}_{C2T} \mathbf{v}_{CRS} \end{aligned}$$

where  $\mathbf{v}_{TRS}$  is a vector in the International Terrestrial Reference System (see IERS Conventions 2003),  $\mathbf{R}_{POM}$  is the polar motion matrix,  $ERA$  is the Earth Rotation Angle,  $\mathbf{R}_{C2I}$  is the matrix  $RC2I$  returned by the present routine, and  $\mathbf{v}_{CRS}$  is a vector in the Geocentric Celestial Reference System.

3. The present routine is faster, but slightly less accurate (about 1 mas), than the `iau_C2I00A` routine.



**REFERENCES :**

1. Capitaine, N., Chapront, J., Lambert, S. and Wallace, P., 2003, *Astron.Astrophys.* **400**, 1145-1154.
2. McCarthy, D.D., Petit, G. (eds.), 2004, *IERS Conventions (2003)*, IERS Technical Note No. 32, BKG.

---

<b>iau_C2IBPN</b>	<i>C2I matrix from BPN matrix</i>	<b>iau_C2IBPN</b>
-------------------	-----------------------------------	-------------------

---

**CALL :**

CALL iau\_C2IBPN ( DATE1, DATE2, RBPN, RC2I )

**ACTION :**

Form the celestial-to-intermediate matrix for a given date given the bias-precession-nutation matrix. IAU 2000.

**GIVEN :**

<i>DATE1</i>	d	TT as a two-part...
<i>DATE2</i>	d	... Julian Date (Note 1)
<i>RBPN</i>	d(3,3)	celestial-to-true matrix (Note 2)

**RETURNED :**

<i>RC2I</i>	d(3,3)	celestial-to-intermediate matrix (Note 3)
-------------	--------	---

**NOTES :**

1. The TT date DATE1+DATE2 is a Julian Date, apportioned in any convenient way between the arguments DATE1 and DATE2. For example, JD(TT) = 2450123.7 could be expressed in any of these ways, among others:

DATE1	DATE2	
2450123.7D0	0D0	(JD method)
2451545.0D0	-1421.3D0	(J2000 method)
2400000.5D0	50123.2D0	(MJD method)
2450123.5D0	0.2D0	(date & time method)

The JD method is the most natural and convenient to use in cases where the loss of several decimal digits of resolution is acceptable. The J2000 method is best matched to the way the argument is handled internally and will deliver the optimum resolution. The MJD method and the date & time methods are both good compromises between resolution and convenience.

2. The matrix RBPN transforms vectors from GCRS to true equator (and CIO or equinox) of date. Only the CIP (bottom row) is used.
3. The matrix RC2I is the first stage in the transformation from celestial to terrestrial coordinates:

$$\begin{aligned} \mathbf{v}_{TRS} &= \mathbf{R}_{POM} \mathbf{R}_3(ERA) \mathbf{R}_{C2I} \mathbf{v}_{CRS} \\ &\equiv \mathbf{R}_{C2T} \mathbf{v}_{CRS} \end{aligned}$$

where  $\mathbf{v}_{TRS}$  is a vector in the International Terrestrial Reference System (see IERS Conventions 2003),  $\mathbf{R}_{POM}$  is the polar motion matrix,  $ERA$  is the Earth Rotation Angle,  $\mathbf{R}_{C2I}$  is the matrix RC2I returned by the present routine, and  $\mathbf{v}_{CRS}$  is a vector in the Geocentric Celestial Reference System.

4. Although its name does not include “00”, this routine is in fact specific to the IAU 2000 models.

**REFERENCES :**

1. Capitaine, N., Chapront, J., Lambert, S. and Wallace, P., 2003, *Astron.Astrophys.* **400**, 1145-1154.
2. McCarthy, D.D., Petit, G. (eds.), 2004, *IERS Conventions (2003)*, IERS Technical Note No. 32, BKG.

---

**iau\_C2T00A** *C2T matrix, IAU 2000A* **iau\_C2T00A**

---

**CALL :**

CALL iau\_C2T00A ( TTA, TTB, UTA, UTB, XP, YP, RC2T )

**ACTION :**

Form the celestial to terrestrial matrix given the date, the UT1 and the polar motion, using the IAU 2000A precession-nutation model.

**GIVEN :**

<i>TTA, TTB</i>	d	TT as a two-part Julian Date (Note 1)
<i>UTA, UTB</i>	d	UT1 as a two-part Julian Date (Note 1)
<i>XP, YP</i>	d	coordinates of the pole (radians, Note 2)

**RETURNED :**

<i>RC2T</i>	d(3,3)	celestial-to-terrestrial matrix (Note 3)
-------------	--------	--

**NOTES :**

1. The TT and UT1 dates TTA+TTB and UTA+UTB are Julian Dates, apportioned in any convenient way between the arguments UTA and UTB. For example, JD(UT1) = 2450123.7 could be expressed in any of these ways, among others:

UTA	UTB	
2450123.7D0	0D0	(JD method)
2451545.0D0	-1421.3D0	(J2000 method)
2400000.5D0	50123.2D0	(MJD method)
2450123.5D0	0.2D0	(date & time method)

The JD method is the most natural and convenient to use in cases where the loss of several decimal digits of resolution is acceptable. The J2000 and MJD methods are good compromises between resolution and convenience. In the case of UTA, UTB, the date & time method is best matched to the Earth rotation angle algorithm used: maximum accuracy (or, at least, minimum noise) is delivered when the UTA argument is for 0<sup>h</sup> UT1 on the day in question and the UTB argument lies in the range 0 to 1, or *vice versa*.

2. XP and YP are the coordinates (in radians) of the Celestial Intermediate Pole with respect to the International Terrestrial Reference System (see IERS Conventions 2003), measured along the meridians 0° and 90° west respectively.
3. The matrix RC2T transforms from celestial to terrestrial coordinates:

$$\begin{aligned} \mathbf{v}_{TRS} &= \mathbf{R}_{POM} \mathbf{R}_3(ERA) \mathbf{R}_{C2I} \mathbf{v}_{CRS} \\ &\equiv \mathbf{R}_{C2T} \mathbf{v}_{CRS} \end{aligned}$$

where  $\mathbf{v}_{TRS}$  is a vector in the International Terrestrial Reference System (see IERS Conventions 2003),  $\mathbf{R}_{POM}$  is the polar motion matrix,  $ERA$  is the Earth Rotation Angle,  $\mathbf{R}_{C2I}$  is the CIO based bias-precession-nutation matrix,  $\mathbf{v}_{CRS}$  is a vector in the Geocentric Celestial Reference System, and  $\mathbf{R}_{C2T}$  is the RC2T matrix returned by the present routine.

4. A faster, but slightly less accurate, result (about 1 mas) can be obtained by using instead the `iau_C2T00B` routine.

**REFERENCE :**

McCarthy, D.D., Petit, G. (eds.), 2004, IERS Conventions (2003), IERS Technical Note No. 32, BKG.

---

**iau\_C2T00B** *C2T matrix, IAU 2000B* **iau\_C2T00B**

---

**CALL :**

CALL iau\_C2T00B ( TTA, TTB, UTA, UTB, XP, YP, RC2T )

**ACTION :**

Form the celestial to terrestrial matrix given the date, the UT1 and the polar motion, using the IAU 2000B precession-nutation model.

**GIVEN :**

<i>TTA, TTB</i>	d	TT as a two-part Julian Date (Note 1)
<i>UTA, UTB</i>	d	UT1 as a two-part Julian Date (Note 1)
<i>XP, YP</i>	d	coordinates of the pole (radians, Note 2)

**RETURNED :**

<i>RC2T</i>	d(3,3)	celestial-to-terrestrial matrix (Note 3)
-------------	--------	--

**NOTES :**

1. The TT and UT1 dates TTA+TTB and UTA+UTB are Julian Dates, apportioned in any convenient way between the arguments UTA and UTB. For example, JD(UT1) = 2450123.7 could be expressed in any of these ways, among others:

UTA	UTB	
2450123.7D0	0D0	(JD method)
2451545.0D0	-1421.3D0	(J2000 method)
2400000.5D0	50123.2D0	(MJD method)
2450123.5D0	0.2D0	(date & time method)

The JD method is the most natural and convenient to use in cases where the loss of several decimal digits of resolution is acceptable. The J2000 and MJD methods are good compromises between resolution and convenience. In the case of UTA, UTB, the date & time method is best matched to the Earth rotation angle algorithm used: maximum accuracy (or, at least, minimum noise) is delivered when the UTA argument is for 0<sup>h</sup> UT1 on the day in question and the UTB argument lies in the range 0 to 1, or *vice versa*.

2. XP and YP are the coordinates (in radians) of the Celestial Intermediate Pole with respect to the International Terrestrial Reference System (see IERS Conventions 2003), measured along the meridians 0° and 90° west respectively.
3. The matrix RC2T transforms from celestial to terrestrial coordinates:

$$\begin{aligned} \mathbf{v}_{TRS} &= \mathbf{R}_{POM} \mathbf{R}_3(ERA) \mathbf{R}_{C2I} \mathbf{v}_{CRS} \\ &\equiv \mathbf{R}_{C2T} \mathbf{v}_{CRS} \end{aligned}$$

where  $\mathbf{v}_{TRS}$  is a vector in the International Terrestrial Reference System (see IERS Conventions 2003),  $\mathbf{R}_{POM}$  is the polar motion matrix,  $ERA$  is the Earth Rotation Angle,  $\mathbf{R}_{C2I}$  is the CIO based bias-precession-nutation matrix,  $\mathbf{v}_{CRS}$  is a vector in the Geocentric Celestial Reference System, and  $\mathbf{R}_{C2T}$  is the RC2T matrix returned by the present routine.

4. The present routine is faster, but slightly less accurate (about 1 mas), than the `iau_C2T00A` routine.

**REFERENCE :**

McCarthy, D.D., Petit, G. (eds.), 2004, IERS Conventions (2003), IERS Technical Note No. 32, BKG.

---

**iau\_C2TEQX**    *C2T matrix from equinox based components*    **iau\_C2TEQX**

---

**CALL :**

CALL iau\_C2TEQX ( RBPN, GST, RPOM, RC2T )

**ACTION :**

Assemble the celestial to terrestrial matrix from equinox based components, namely the celestial-to-true matrix, the Greenwich Apparent Sidereal Time and the polar motion matrix.

**GIVEN :**

<i>RBPN</i>	d(3,3)	celestial-to-true matrix
<i>GST</i>	d	Greenwich (apparent) Sidereal Time (radians)
<i>RPOM</i>	d(3,3)	polar-motion matrix

**RETURNED :**

<i>RC2T</i>	d(3,3)	celestial-to-terrestrial matrix (Note 2)
-------------	--------	--

**NOTES :**

1. This routine constructs the rotation matrix that transforms vectors in the celestial system into vectors in the terrestrial system. It does so starting from precomputed components, namely the matrix which rotates from celestial coordinates to the true equator and equinox of date, the Greenwich Apparent Sidereal Time and the polar motion matrix. One use of the present routine is when generating a series of celestial-to-terrestrial matrices where only the Sidereal Time changes, avoiding the considerable overhead of recomputing the precession-nutation more often than necessary to achieve given accuracy objectives.
2. The matrix RC2T transforms from celestial to terrestrial coordinates:

$$\begin{aligned} \mathbf{v}_{TRS} &= \mathbf{R}_{POM} \mathbf{R}_3(ERA) \mathbf{R}_{C2I} \mathbf{v}_{CRS} \\ &\equiv \mathbf{R}_{C2T} \mathbf{v}_{CRS} \end{aligned}$$

where  $\mathbf{v}_{TRS}$  is a vector in the International Terrestrial Reference System (see IERS Conventions 2003),  $\mathbf{R}_{POM}$  is the polar motion matrix,  $ERA$  is the Earth Rotation Angle,  $\mathbf{R}_{C2I}$  is the CIO based bias-precession-nutation matrix,  $\mathbf{v}_{CRS}$  is a vector in the Geocentric Celestial Reference System, and  $\mathbf{R}_{C2T}$  is the RC2T matrix returned by the present routine.

**REFERENCE :**

McCarthy, D.D., Petit, G. (eds.), 2004, IERS Conventions (2003), IERS Technical Note No. 32, BKG.



---

**iau\_C2TPE**      *C2T matrix from nutation etc., IAU 2000*      **iau\_C2TPE**

---

**CALL :**

CALL iau\_C2TPE ( TTA, TTb, UTA, UTb, DPSI, DEPS, XP, YP,

**ACTION :**

Form the celestial to terrestrial matrix given the date, the UT1, the nutation and the polar motion. IAU 2000.

**GIVEN :**

<i>TTA,TTb</i>	d	TT as a two-part Julian Date (Note 1)
<i>UTA,UTb</i>	d	UT1 as a two-part Julian Date (Note 1)
<i>DPSI,DEPS</i>	d	nutation (Note 2)
<i>XP,YP</i>	d	coordinates of the pole (radians, Note 3)

**RETURNED :**

<i>RC2T</i>	d(3,3)	celestial-to-terrestrial matrix (Note 4)
-------------	--------	--

**NOTES :**

1. The TT and UT1 dates *TTA+TTb* and *UTA+UTb* are Julian Dates, apportioned in any convenient way between the arguments *UTA* and *UTb*. For example,  $JD(UT1) = 2450123.7$  could be expressed in any of these ways, among others:

UTA	UTb	
2450123.7D0	0D0	(JD method)
2451545.0D0	-1421.3D0	(J2000 method)
2400000.5D0	50123.2D0	(MJD method)
2450123.5D0	0.2D0	(date & time method)

- The JD method is the most natural and convenient to use in cases where the loss of several decimal digits of resolution is acceptable. The J2000 and MJD methods are good compromises between resolution and convenience. In the case of *UTA, UTb*, the date & time method is best matched to the Earth rotation angle algorithm used: maximum accuracy (or, at least, minimum noise) is delivered when the *UTA* argument is for 0<sup>h</sup> UT1 on the day in question and the *UTb* argument lies in the range 0 to 1, or *vice versa*.
2. The caller is responsible for providing the nutation components; they are in longitude and obliquity, in radians and are with respect to the equinox and ecliptic of date. For high-accuracy applications, free core nutation should be included as well as any other relevant corrections to the position of the CIP.
  3. *XP* and *YP* are the coordinates (in radians) of the Celestial Intermediate Pole with respect to the International Terrestrial Reference System (see IERS Conventions 2003), measured along the meridians 0° and 90° west respectively.

4. The matrix **RC2T** transforms from celestial to terrestrial coordinates:

$$\begin{aligned}\mathbf{v}_{TRS} &= \mathbf{R}_{POM} \mathbf{R}_3(GST) \mathbf{R}_{BPN} \mathbf{v}_{CRS} \\ &= \mathbf{R}_{C2T} \mathbf{v}_{CRS}\end{aligned}$$

where  $\mathbf{v}_{TRS}$  is a vector in the International Terrestrial Reference System (see IERS Conventions 2003),  $\mathbf{R}_{POM}$  is the polar motion matrix,  $GST$  is the Greenwich (apparent) Sidereal Time,  $\mathbf{R}_{BPN}$  is the equinox based bias-precession-nutation matrix,  $\mathbf{v}_{CRS}$  is a vector in the Geocentric Celestial Reference System, and  $\mathbf{R}_{C2T}$  is the **RC2T** matrix returned by the present routine.

5. Although its name does not include “00”, this routine is in fact specific to the IAU 2000 models.

#### REFERENCE :

McCarthy, D.D., Petit, G. (eds.), 2004, IERS Conventions (2003), IERS Technical Note No. 32, BKG.

---

**iau\_C2TXY**                      *C2T matrix given CIP X,Y. IAU 2000*                      **iau\_C2TXY**

---

**CALL :**

CALL iau\_C2TXY ( TTA, TTB, UTA, UTB, X, Y, XP, YP, RC2T )

**ACTION :**

Form the celestial to terrestrial matrix given the date, the UT1, the CIP  $X, Y$  coordinates and the polar motion. IAU 2000.

**GIVEN :**

<i>TTA,TTB</i>	d	TT as a two-part Julian Date (Note 1)
<i>UTA,UTB</i>	d	UT1 as a two-part Julian Date (Note 1)
<i>X,Y</i>	d	Celestial Intermediate Pole (Note 2)
<i>XP,YP</i>	d	coordinates of the pole (radians, Note 3)

**RETURNED :**

<i>RC2T</i>	d(3,3)	celestial-to-terrestrial matrix (Note 4)
-------------	--------	--

**NOTES :**

1. The TT and UT1 dates  $TTA+TTB$  and  $UTA+UTB$  are Julian Dates, apportioned in any convenient way between the arguments  $UTA$  and  $UTB$ . For example,  $JD(UT1) = 2450123.7$  could be expressed in any of these ways, among others:

UTA	UTB	
2450123.7D0	0D0	(JD method)
2451545.0D0	-1421.3D0	(J2000 method)
2400000.5D0	50123.2D0	(MJD method)
2450123.5D0	0.2D0	(date & time method)

- The JD method is the most natural and convenient to use in cases where the loss of several decimal digits of resolution is acceptable. The J2000 and MJD methods are good compromises between resolution and convenience. In the case of  $UTA, UTB$ , the date & time method is best matched to the Earth rotation angle algorithm used: maximum accuracy (or, at least, minimum noise) is delivered when the  $UTA$  argument is for  $0^h$  UT1 on the day in question and the  $UTB$  argument lies in the range 0 to 1, or *vice versa*.
2. The Celestial Intermediate Pole coordinates  $X, Y$  are the  $x, y$  components of the unit vector in the Geocentric Celestial Reference System.
  3.  $XP$  and  $YP$  are the coordinates (in radians) of the Celestial Intermediate Pole with respect to the International Terrestrial Reference System (see IERS Conventions 2003), measured along the meridians  $0^\circ$  and  $90^\circ$  west respectively.

4. The matrix **RC2T** transforms from celestial to terrestrial coordinates:

$$\begin{aligned}\mathbf{v}_{TRS} &= \mathbf{R}_{POM} \mathbf{R}_3(GST) \mathbf{R}_{BPN} \mathbf{v}_{CRS} \\ &= \mathbf{R}_{C2T} \mathbf{v}_{CRS}\end{aligned}$$

where  $\mathbf{v}_{TRS}$  is a vector in the International Terrestrial Reference System (see IERS Conventions 2003),  $\mathbf{R}_{POM}$  is the polar motion matrix,  $GST$  is the Greenwich (apparent) Sidereal Time,  $\mathbf{R}_{BPN}$  is the equinox based bias-precession-nutation matrix,  $\mathbf{v}_{CRS}$  is a vector in the Geocentric Celestial Reference System, and  $\mathbf{R}_{C2T}$  is the **RC2T** matrix returned by the present routine.

5. Although its name does not include “00”, this routine is in fact specific to the IAU 2000 models.

#### REFERENCE :

McCarthy, D.D., Petit, G. (eds.), 2004, IERS Conventions (2003), IERS Technical Note No. 32, BKG.

---

**iau\_CAL2JD**                      *Gregorian calendar to Julian Date*                      **iau\_CAL2JD**
**CALL :**

CALL iau\_CAL2JD ( IY, IM, ID, DJMO, DJM, J )

**ACTION :**

Gregorian Calendar to Julian Date.

**GIVEN :**

*IY,IM,ID*    i                      year, month, day in Gregorian calendar (Note 1)

**RETURNED :**

<i>DJMO</i>	d	MJD zero-point: always 2400000.5D0
<i>DJM</i>	d	Modified Julian Date for 0 <sup>h</sup>
<i>J</i>	i	status: 0 = OK
		-1 = bad year (Note 3; JD not computed)
		-2 = bad month (JD not computed)
		-3 = bad day (JD computed)

**NOTES :**

1. The algorithm used is valid from -4800 March 1, but this implementation rejects dates before -4799 January 1.
2. The Julian Date is returned in two pieces, in the usual SOFA manner, which is designed to preserve time resolution. The Julian Date is available as a single number by adding DJMO and DJM.
3. In early eras the conversion is from the "Proleptic Gregorian Calendar"; no account is taken of the date(s) of adoption of the Gregorian Calendar, nor is any AD/BC numbering convention observed.

**REFERENCE :**

Seidelmann, P.K. (Ed.) (1992), *Explanatory Supplement to the Astronomical Almanac*, University Science Books, Section 12.92 (p604).

---

**iau\_CR***copy r-matrix***iau\_CR****CALL :**

CALL iau\_CR ( R, C )

**ACTION :**

Copy an r-matrix.

**GIVEN :** $R$           d(3,3)          r-matrix to be copied**RETURNED :** $C$           d(3,3)          copy

---

<b>iau_DAT</b>	<i>calculate TAI–UTC</i>	<b>iau_DAT</b>
----------------	--------------------------	----------------

**CALL :**

CALL iau\_DAT ( IY, IM, ID, FD, DELTAT, J )

**ACTION :**

For a given UTC date, calculate  $\Delta\text{AT} = \text{TAI} - \text{UTC}$ .

**GIVEN :**

<i>IY</i>	i	UTC: year (Notes 1 and 2)
<i>IM</i>	i	month (Note 2)
<i>ID</i>	i	day (Notes 2 and 3)
<i>FD</i>	d	fraction of day (Note 4)

**RETURNED :**

<i>DELTAT</i>	d	TAI minus UTC, seconds
<i>J</i>	i	status: +1 = dubious year (Note 1)
		0 = OK
		-1 = bad year
		-2 = bad month
		-3 = bad day (Note 3)
		-4 = bad fraction (Note 4)
		-5 = internal error (Note 5)

**NOTES :**

1. UTC began at 1960 January 1.0 (JD 2436934.5) and it is improper to call the routine with an earlier date. If this is attempted, zero is returned together with a warning status.

Because leap seconds cannot, in principle, be predicted in advance, a reliable check for dates beyond the valid range is impossible. To guard against gross errors, a year five or more after the release year of the present routine (see parameter *IYV*) is considered dubious. In this case a warning status is returned but the result is computed in the normal way.

For both too-early and too-late years, the warning status is  $J = +1$ . This is distinct from the error status  $J = -1$ , which signifies a year so early that JD could not be computed.

2. If the specified date is for a day which ends with a leap second, the TAI–UTC value returned is for the period leading up to the leap second. If the date is for a day which begins as a leap second ends, the TAI–UTC returned is for the period following the leap second.

3. The day number must be in the normal calendar range, for example 1 through 30 for April. The “almanac” convention of allowing such dates as January 0 and December 32 is not supported in this routine, in order to avoid confusion near leap seconds.
4. The fraction of day is used only for dates before the introduction of leap seconds, the first of which occurred at the end of 1971. It is tested for validity (0 to 1 is the valid range) even if not used; if invalid, zero is used and status  $J = -4$  is returned. For many applications, setting FD to zero is acceptable; the resulting error is always less than 3 ms (and occurs only pre-1972).
5. The status value returned in the case where there are multiple errors refers to the first error detected. For example, if the month and day are 13 and 32 respectively,  $J = -2$  (bad month) will be returned. The “internal error” status refers to a case that is impossible but causes some compilers to issue a warning.
6. In cases where a valid result is not available, zero is returned.

#### REFERENCES :

1. For dates from 1961 January 1 onwards, the expressions from the file `ftp://maia.usno.navy.mil/ser7/TAI-UTC.dat` are used.
2. The 5ms timestep at 1961 January 1 is taken from 2.58.1 (p87) of *Explanatory Supplement to the Astronomical Almanac*, ed. P. Kenneth Seidelmann (1992), University Science Books.



---

**iau\_EE00**      *equation of the equinoxes from  $\Delta\psi \cos \epsilon$ , IAU 2000*      **iau\_EE00**

**CALL :**

D = iau\_EE00 ( DATE1, DATE2, EPSA, DPSI )

**ACTION :**

The equation of the equinoxes, compatible with IAU 2000 resolutions, given the nutation in longitude and the mean obliquity.

**GIVEN :**

<i>DATE1</i>	d	TT as a two-part...
<i>DATE2</i>	d	... Julian Date (Note 1)
<i>EPSA</i>	d	mean obliquity (Note 2)
<i>DPSI</i>	d	nutation in longitude (Note 3)

**RETURNED** (function value) :

d                      equation of the equinoxes (Note 4)

**NOTES :**

1. The TT date DATE1+DATE2 is a Julian Date, apportioned in any convenient way between the arguments DATE1 and DATE2. For example,  $JD(TT) = 2450123.7$  could be expressed in any of these ways, among others:

DATE1	DATE2	
2450123.7D0	0D0	(JD method)
2451545.0D0	-1421.3D0	(J2000 method)
2400000.5D0	50123.2D0	(MJD method)
2450123.5D0	0.2D0	(date & time method)

- The JD method is the most natural and convenient to use in cases where the loss of several decimal digits of resolution is acceptable. The J2000 method is best matched to the way the argument is handled internally and will deliver the optimum resolution. The MJD method and the date & time methods are both good compromises between resolution and convenience.
2. The obliquity, in radians, is mean of date.
  3. The result, which is in radians, operates in the following sense:
 

Greenwich apparent ST = GMST + equation of the equinoxes
  4. The result is compatible with the IAU 2000 resolutions. For further details, see IERS Conventions 2003 and Capitaine *et al.* (2002).

**REFERENCES :**

1. Capitaine, N., Wallace, P.T. & McCarthy, D.D., 2003, *Astron.Astrophys.*, **406**, 1135-1149.
2. McCarthy, D.D., Petit, G. (eds.), 2004, *IERS Conventions (2003)*, IERS Technical Note No. 32, BKG.

---

**iau\_EE00A**                      *equation of the equinoxes, IAU 2000A*                      **iau\_EE00A**

**CALL :**

D = iau\_EE00A ( DATE1, DATE2 )

**ACTION :**

Equation of the equinoxes, compatible with IAU 2000 resolutions.

**GIVEN :**

<i>DATE1</i>	d	TT as a two-part...
<i>DATE2</i>	d	... Julian Date (Note 1)

**RETURNED** (function value) :

d	equation of the equinoxes (Note 2)
---	------------------------------------

**NOTES :**

1. The TT date DATE1+DATE2 is a Julian Date, apportioned in any convenient way between the arguments DATE1 and DATE2. For example, JD(TT) = 2450123.7 could be expressed in any of these ways, among others:

DATE1	DATE2	
2450123.7D0	0D0	(JD method)
2451545.0D0	-1421.3D0	(J2000 method)
2400000.5D0	50123.2D0	(MJD method)
2450123.5D0	0.2D0	(date & time method)

The JD method is the most natural and convenient to use in cases where the loss of several decimal digits of resolution is acceptable. The J2000 method is best matched to the way the argument is handled internally and will deliver the optimum resolution. The MJD method and the date & time methods are both good compromises between resolution and convenience.

2. The result, which is in radians, operates in the following sense:

Greenwich apparent ST = GMST + equation of the equinoxes

3. The result is compatible with the IAU 2000 resolutions. For further details, see IERS Conventions 2003 and Capitaine *et al.* (2002).
4. A faster, but slightly less accurate, result (about 1 mas) can be obtained by using instead the iau\_EE00B routine.

**REFERENCES :**

1. Capitaine, N., Wallace, P.T. & McCarthy, D.D., 2003, *Astron.Astrophys.*, **406**, 1135-1149.
2. McCarthy, D.D., Petit, G. (eds.), 2004, *IERS Conventions (2003)*, IERS Technical Note No. 32, BKG.

---

**iau\_EE00B**                      *equation of the equinoxes, IAU 2000B*                      **iau\_EE00B**

**CALL :**

D = iau\_EE00B ( DATE1, DATE2 )

**ACTION :**

Equation of the equinoxes, compatible with IAU 2000 resolutions but using the truncated nutation model IAU 2000B.

**GIVEN :**

*DATE1*      d                      TT as a two-part...  
*DATE2*      d                      ... Julian Date (Note 1)

**RETURNED** (function value) :

d                      equation of the equinoxes (Note 2)

**NOTES :**

1. The TT date DATE1+DATE2 is a Julian Date, apportioned in any convenient way between the arguments DATE1 and DATE2. For example, JD(TT) = 2450123.7 could be expressed in any of these ways, among others:

DATE1	DATE2	
2450123.7D0	0D0	(JD method)
2451545.0D0	-1421.3D0	(J2000 method)
2400000.5D0	50123.2D0	(MJD method)
2450123.5D0	0.2D0	(date & time method)

The JD method is the most natural and convenient to use in cases where the loss of several decimal digits of resolution is acceptable. The J2000 method is best matched to the way the argument is handled internally and will deliver the optimum resolution. The MJD method and the date & time methods are both good compromises between resolution and convenience.

2. The result, which is in radians, operates in the following sense:

Greenwich apparent ST = GMST + equation of the equinoxes

3. The result is compatible with the IAU 2000 resolutions except that accuracy has been compromised (1 mas) for the sake of speed. For further details, see McCarthy & Luzum (2003), IERS Conventions 2003 and Capitaine *et al.* (2003).

**REFERENCES :**

1. Capitaine, N., Wallace, P.T. & McCarthy, D.D., 2003, *Astron.Astrophys.*, **406**, 1135-1149.
2. McCarthy, D.D. & Luzum, B.J., 2003, *Celestial Mechanics & Dynamical Astronomy*, **85**, 37-49.
3. McCarthy, D.D., Petit, G. (eds.), 2004, *IERS Conventions (2003)*, IERS Technical Note No. 32, BKG.

---

**iau\_EE06A**      *equation of the equinoxes, IAU 2006/2000A*      **iau\_EE06A**

**CALL :**

D = iau\_EE06A ( DATE1, DATE2 )

**ACTION :**

Equation of the equinoxes, compatible with IAU 2000 resolutions and IAU 2006/2000A precession-nutation.

**GIVEN :**

<i>DATE1</i>	d	TT as a two-part...
<i>DATE2</i>	d	... Julian Date (Note 1)

**RETURNED** (function value) :

d	equation of the equinoxes (Note 2)
---	------------------------------------

**NOTES :**

- The TT date DATE1+DATE2 is a Julian Date, apportioned in any convenient way between the arguments DATE1 and DATE2. For example,  $JD(TT) = 2450123.7$  could be expressed in any of these ways, among others:

DATE1	DATE2	
2450123.7D0	0D0	(JD method)
2451545.0D0	-1421.3D0	(J2000 method)
2400000.5D0	50123.2D0	(MJD method)
2450123.5D0	0.2D0	(date & time method)

The JD method is the most natural and convenient to use in cases where the loss of several decimal digits of resolution is acceptable. The J2000 method is best matched to the way the argument is handled internally and will deliver the optimum resolution. The MJD method and the date & time methods are both good compromises between resolution and convenience.

- The result, which is in radians, operates in the following sense:

Greenwich apparent ST = GMST + equation of the equinoxes

**REFERENCE :**

McCarthy, D.D., Petit, G. (eds.), 2004, IERS Conventions (2003), IERS Technical Note No. 32, BKG.

---

**iau\_EECT00** *eqn.equinoxes complementary terms, IAU 2000* **iau\_EECT00**
**CALL :**

D = iau\_EECT00 ( DATE1, DATE2 )

**ACTION :**

Equation of the equinoxes complementary terms, consistent with IAU 2000 resolutions.

**GIVEN :**

DATE1      d                    TT as a two-part...  
 DATE2      d                    ... Julian Date (Note 1)

**RETURNED** (function value) :

d                    complementary terms (Note 2)

**NOTES :**

1. The TT date DATE1+DATE2 is a Julian Date, apportioned in any convenient way between the arguments DATE1 and DATE2. For example, JD(TT) = 2450123.7 could be expressed in any of these ways, among others:

DATE1	DATE2	
2450123.7D0	0D0	(JD method)
2451545.0D0	-1421.3D0	(J2000 method)
2400000.5D0	50123.2D0	(MJD method)
2450123.5D0	0.2D0	(date & time method)

The JD method is the most natural and convenient to use in cases where the loss of several decimal digits of resolution is acceptable. The J2000 method is best matched to the way the argument is handled internally and will deliver the optimum resolution. The MJD method and the date & time methods are both good compromises between resolution and convenience.

2. The “complementary terms” are part of the equation of the equinoxes (EE), classically the difference between apparent and mean Sidereal Time:

$$\text{GAST} = \text{GMST} + \text{EE}$$

with:

$$\text{EE} = \Delta\psi \cos \epsilon$$

where  $\Delta\psi$  is the nutation in longitude and  $\epsilon$  is the obliquity of date. However, if the rotation of the Earth were constant in an inertial frame the classical formulation would lead to apparent irregularities in the UT1 time scale traceable to side-effects of precession-nutation. In order to eliminate these effects from UT1, “complementary terms” were introduced in 1994 (IAU, 1994) and took effect from 1997 (Capitaine & Gontier, 1993):

$$\text{GAST} = \text{GMST} + \text{CT} + \text{EE}$$

By convention, the complementary terms are included as part of the equation of the equinoxes rather than as part of the mean Sidereal Time. This slightly compromises the “geometrical” interpretation of mean sidereal time but is otherwise inconsequential.

The present routine computes CT in the above expression, compatible with IAU 2000 resolutions (Capitaine *et al.*, 2002, and IERS Conventions 2003).

#### REFERENCES :

1. Capitaine, N. & Gontier, A.-M., 1993, *Astron.Astrophys.*, **275**, 645-650.
2. Capitaine, N., Wallace, P.T. & McCarthy, D.D., 2003, *Astron.Astrophys.*, **406**, 1135-1149.
3. IAU Resolution C7, Recommendation 3, 1994.
4. McCarthy, D.D., Petit, G. (eds.), 2004, *IERS Conventions (2003)*, IERS Technical Note No. 32, BKG.

---

**iau\_EO06A**                      *equation of the origins, IAU 2006/2000A*                      **iau\_EO06A**

**CALL :**

D = iau\_EO06A ( DATE1, DATE2 )

**ACTION :**

Equation of the origins, IAU 2006 precession and IAU 2000A nutation.

**GIVEN :**

<i>DATE1</i>	d	TT as a two-part...
<i>DATE2</i>	d	... Julian Date (Note 1)

**RETURNED** (function value) :

d	the equation of the origins in radians
---	--

**NOTES :**

1. The TT date DATE1+DATE2 is a Julian Date, apportioned in any convenient way between the arguments DATE1 and DATE2. For example,  $JD(TT) = 2450123.7$  could be expressed in any of these ways, among others:

DATE1	DATE2	
2450123.7D0	0D0	(JD method)
2451545.0D0	-1421.3D0	(J2000 method)
2400000.5D0	50123.2D0	(MJD method)
2450123.5D0	0.2D0	(date & time method)

The JD method is the most natural and convenient to use in cases where the loss of several decimal digits of resolution is acceptable. The J2000 method is best matched to the way the argument is handled internally and will deliver the optimum resolution. The MJD method and the date & time methods are both good compromises between resolution and convenience.

2. The equation of the origins is the distance between the true equinox and the celestial intermediate origin and, equivalently, the difference between Earth rotation angle and Greenwich apparent sidereal time (ERA-GST). It comprises the precession (since J2000.0) in right ascension plus the equation of the equinoxes (including the small correction terms).

**REFERENCES :**

1. Capitaine, N. & Wallace, P.T., 2006, *Astron.Astrophys.*, **450**, 855-872.
2. Wallace, P.T. & Capitaine, N., 2006, *Astron.Astrophys.*, **459**, 981-985.

---

**iau\_EORS**      *equation of the origins from NPB matrix and s*      **iau\_EORS**

**CALL :**

D = iau\_EORS ( RNPB, S )

**ACTION :**

Equation of the origins, given the classical NPB matrix and the quantity *s*.

**GIVEN :**

<i>RNPB</i>	d(3,3)	classical nutation × precession × bias matrix
<i>S</i>	d	the quantity <i>s</i> (the CIO locator) in radians

**RETURNED** (function value) :

d                      the equation of the origins in radians

**NOTES :**

1. The equation of the origins is the distance between the true equinox and the celestial intermediate origin and, equivalently, the difference between Earth rotation angle and Greenwich apparent sidereal time (ERA–GST). It comprises the precession (since J2000.0) in right ascension plus the equation of the equinoxes (including the small correction terms).
2. The algorithm is from Wallace & Capitaine (2006).

**REFERENCES :**

1. Capitaine, N. & Wallace, P.T., 2006, *Astron.Astrophys.*, **450**, 855-872.
2. Wallace, P.T. & Capitaine, N., 2006, *Astron.Astrophys.*, **459**, 981-985.



---

**iau\_EQEQ94**                      *equation of the equinoxes, IAU 1994*                      **iau\_EQEQ94**
**CALL :**

D = iau\_EQEQ94 ( DATE1, DATE2 )

**ACTION :**

Equation of the equinoxes, IAU 1994 model.

**GIVEN :**

<i>DATE1</i>	d	TDB as a two-part...
<i>DATE2</i>	d	... Julian Date (Note 1)

**RETURNED** (function value) :

d                      equation of the equinoxes (Note 2)

**NOTES :**

1. The TDB date DATE1+DATE2 is a Julian Date, apportioned in any convenient way between the arguments DATE1 and DATE2. For example, JD(TDB) = 2450123.7 could be expressed in any of these ways, among others:

DATE1	DATE2	
2450123.7D0	0D0	(JD method)
2451545.0D0	-1421.3D0	(J2000 method)
2400000.5D0	50123.2D0	(MJD method)
2450123.5D0	0.2D0	(date & time method)

The JD method is the most natural and convenient to use in cases where the loss of several decimal digits of resolution is acceptable. The J2000 method is best matched to the way the argument is handled internally and will deliver the optimum resolution. The MJD method and the date & time methods are both good compromises between resolution and convenience.

2. The result, which is in radians, operates in the following sense:

Greenwich apparent ST = GMST + equation of the equinoxes

**REFERENCES :**

1. IAU Resolution C7, Recommendation 3, 1994.
2. Capitaine, N. & Gontier, A.-M., 1993, *Astron.Astrophys.*, **275**, 645-650.

---

<b>iau_ERA00</b>	<i>Earth rotation angle, IAU 2000</i>	<b>iau_ERA00</b>
------------------	---------------------------------------	------------------

**CALL :**

D = iau\_ERA00 ( DJ1, DJ2 )

**ACTION :**

Earth rotation angle (IAU 2000 model).

**GIVEN :**

<i>DJ1</i>	d	UT1 as a two-part...
<i>DJ2</i>	d	... Julian Date (Note 1)

**RETURNED** (function value) :

d	ERA in radians (Note 2)
---	-------------------------

**NOTES :**

1. The UT1 date DJ1+DJ2 is a Julian Date, apportioned in any convenient way between the arguments DJ1 and DJ2. For example,  $JD(UT1) = 2450123.7$  could be expressed in any of these ways, among others:

DATE1	DATE2	
2450123.7D0	0D0	(JD method)
2451545.0D0	-1421.3D0	(J2000 method)
2400000.5D0	50123.2D0	(MJD method)
2450123.5D0	0.2D0	(date & time method)

The JD method is the most natural and convenient to use in cases where the loss of several decimal digits of resolution is acceptable. The J2000 and MJD methods are good compromises between resolution and convenience. The date & time method is best matched to the algorithm used: maximum accuracy (or, at least, minimum noise) is delivered when the DJ1 argument is for 0<sup>h</sup> UT1 on the day in question and the DJ2 argument lies in the range 0 to 1, or *vice versa*.

2. The algorithm is adapted from Expression 22 of Capitaine *et al.* 2000. The time argument has been expressed in days directly, and, to retain precision, integer contributions have been eliminated. The same formulation is given in IERS Conventions (2003), Chap. 5, Eq. 14.

**REFERENCES :**

1. Capitaine, N., Guinot, B. & McCarthy, D.D., 2000, *Astron. Astrophys.*, **355**, 398-405.
2. McCarthy, D.D., Petit, G. (eds.), 2004, *IERS Conventions (2003)*, IERS Technical Note No. 32, BKG.

---

**iau\_FAD03**    *mean elongation of Moon from Sun, IERS 2003*    **iau\_FAD03****CALL :**

D = iau\_FAD03 ( T )

**ACTION :**

Fundamental argument, IERS Conventions (2003): mean elongation of the Moon from the Sun.

**GIVEN :**

*T*            d            TDB, Julian centuries since J2000.0 (Note 1)

**RETURNED** (function value) :

d            mean elongation of Moon from Sun, radians (Note 2)

**NOTES :**

1. Though *T* is strictly TDB, it is usually more convenient to use TT, which makes no significant difference.
2. The expression used is as adopted in IERS Conventions (2003) and is from Simon *et al.* (1994).

**REFERENCES :**

1. McCarthy, D.D., Petit, G. (eds.), 2004, IERS Conventions (2003), IERS Technical Note No. 32, BKG.
2. Simon, J.-L., Bretagnon, P., Chapront, J., Chapront-Touzé, M., Francou, G & Laskar J., 1994, *Astron.Astrophys.*, **282**, 663-683.

---

**iau\_FAE03**                      *mean longitude of Earth, IERS 2003*                      **iau\_FAE03**

**CALL :**

D = iau\_FAE03 ( T )

**ACTION :**

Fundamental argument, IERS Conventions (2003): mean longitude of Earth.

**GIVEN :**

T                      d                      TDB, Julian centuries since J2000.0 (Note 1)

**RETURNED** (function value) :

d                      mean longitude of Earth, radians (Note 2)

**NOTES :**

1. Though T is strictly TDB, it is usually more convenient to use TT, which makes no significant difference.
2. The expression used is as adopted in IERS Conventions (2003) and comes from Souchay *et al.* (1999) after Simon *et al.* (1994).

**REFERENCES :**

1. McCarthy, D.D., Petit, G. (eds.), 2004, IERS Conventions (2003), IERS Technical Note No. 32, BKG.
2. Simon, J.-L., Bretagnon, P., Chapront, J., Chapront-Touzé, M., Francou, G & Laskar J., 1994, *Astron.Astrophys.*, **282**, 663-683.
3. Souchay, J., Loysel, B., Kinoshita, H., Folgueira, M., 1999, *Astron.Astrophys.Supp.Ser.* **135**, 111.

---

**iau\_FAF03**    *mean long. of Moon minus asc. node, IERS 2003*    **iau\_FAF03**

**CALL :**

D = iau\_FAF03 ( T )

**ACTION :**

Fundamental argument, IERS Conventions (2003): mean longitude of the Moon minus mean longitude of the ascending node.

**GIVEN :**

T            d            TDB, Julian centuries since J2000.0 (Note 1)

**RETURNED** (function value) :

d            mean long. of Moon minus asc. node, radians (Note 2)

**NOTES :**

1. Though T is strictly TDB, it is usually more convenient to use TT, which makes no significant difference.
2. The expression used is as adopted in IERS Conventions (2003) and is from Simon *et al.* (1994).

**REFERENCES :**

1. McCarthy, D.D., Petit, G. (eds.), 2004, IERS Conventions (2003), IERS Technical Note No. 32, BKG.
2. Simon, J.-L., Bretagnon, P., Chapront, J., Chapront-Touzé, M., Francou, G & Laskar J., 1994, *Astron.Astrophys.*, **282**, 663-683.

---

**iau\_FAJU03**      *mean longitude of Jupiter, IERS 2003*      **iau\_FAJU03**

**CALL :**

D = iau\_FAJU03 ( T )

**ACTION :**

Fundamental argument, IERS Conventions (2003): mean longitude of Jupiter.

**GIVEN :**

T            d            TDB, Julian centuries since J2000.0 (Note 1)

**RETURNED** (function value) :

d            mean longitude of Jupiter, radians (Note 2)

**NOTES :**

1. Though T is strictly TDB, it is usually more convenient to use TT, which makes no significant difference.
2. The expression used is as adopted in IERS Conventions (2003) and comes from Souchay *et al.* (1999) after Simon *et al.* (1994).

**REFERENCES :**

1. McCarthy, D.D., Petit, G. (eds.), 2004, IERS Conventions (2003), IERS Technical Note No. 32, BKG.
2. Simon, J.-L., Bretagnon, P., Chapront, J., Chapront-Touzé, M., Francou, G & Laskar J., 1994, *Astron.Astrophys.*, **282**, 663-683.
3. Souchay, J., Loysel, B., Kinoshita, H., Folgueira, M., 1999, *Astron.Astrophys.Supp.Ser.* **135**, 111.

---

**iau\_FAL03**                      *mean anomaly of Moon, IERS 2003*                      **iau\_FAL03**

**CALL :**

D = iau\_FAL03 ( T )

**ACTION :**

Fundamental argument, IERS Conventions (2003): mean anomaly of the Moon.

**GIVEN :**

T                      d                      TDB, Julian centuries since J2000.0 (Note 1)

**RETURNED** (function value) :

d                      mean anomaly of the Moon, radians (Note 2)

**NOTES :**

1. Though T is strictly TDB, it is usually more convenient to use TT, which makes no significant difference.
2. The expression used is as adopted in IERS Conventions (2003) and is from Simon *et al.* (1994).

**REFERENCES :**

1. McCarthy, D.D., Petit, G. (eds.), 2004, IERS Conventions (2003), IERS Technical Note No. 32, BKG.
2. Simon, J.-L., Bretagnon, P., Chapront, J., Chapront-Touzé, M., Francou, G & Laskar J., 1994, *Astron.Astrophys.*, **282**, 663-683.

---

**iau\_FALP03**                      *mean anomaly of Sun, IERS 2003*                      **iau\_FALP03**

**CALL :**

D = iau\_FALP03 ( T )

**ACTION :**

Fundamental argument, IERS Conventions (2003): mean anomaly of the Sun.

**GIVEN :**

T                      d                      TDB, Julian centuries since J2000.0 (Note 1)

**RETURNED** (function value) :

d                      mean anomaly of the Sun, radians (Note 2)

**NOTES :**

1. Though T is strictly TDB, it is usually more convenient to use TT, which makes no significant difference.
2. The expression used is as adopted in IERS Conventions (2003) and is from Simon *et al.* (1994).

**REFERENCES :**

1. McCarthy, D.D., Petit, G. (eds.), 2004, IERS Conventions (2003), IERS Technical Note No. 32, BKG.
2. Simon, J.-L., Bretagnon, P., Chapront, J., Chapront-Touzé, M., Francou, G & Laskar J., 1994, *Astron.Astrophys.*, **282**, 663-683.



---

**iau\_FAMA03**      *mean longitude of Mars, IERS 2003*      **iau\_FAMA03**

**CALL :**

D = iau\_FAMA03 ( T )

**ACTION :**

Fundamental argument, IERS Conventions (2003): mean longitude of Mars.

**GIVEN :**

T                  d                  TDB, Julian centuries since J2000.0 (Note 1)

**RETURNED** (function value) :

d                  mean longitude of Mars, radians (Note 2)

**NOTES :**

1. Though T is strictly TDB, it is usually more convenient to use TT, which makes no significant difference.
2. The expression used is as adopted in IERS Conventions (2003) and comes from Souchay *et al.* (1999) after Simon *et al.* (1994).

**REFERENCES :**

1. McCarthy, D.D., Petit, G. (eds.), 2004, IERS Conventions (2003), IERS Technical Note No. 32, BKG.
2. Simon, J.-L., Bretagnon, P., Chapront, J., Chapront-Touzé, M., Francou, G & Laskar J., 1994, *Astron.Astrophys.*, **282**, 663-683.
3. Souchay, J., Loysel, B., Kinoshita, H., Folgueira, M., 1999, *Astron.Astrophys.Supp.Ser.* **135**, 111.

---

**iau\_FAME03**      *mean longitude of Mercury, IERS 2003*      **iau\_FAME03**

**CALL :**

D = iau\_FAME03 ( T )

**ACTION :**

Fundamental argument, IERS Conventions (2003): mean longitude of Mercury.

**GIVEN :**

T                  d                  TDB, Julian centuries since J2000.0 (Note 1)

**RETURNED** (function value) :

d                  mean longitude of Mercury, radians (Note 2)

**NOTES :**

1. Though T is strictly TDB, it is usually more convenient to use TT, which makes no significant difference.
2. The expression used is as adopted in IERS Conventions (2003) and comes from Souchay *et al.* (1999) after Simon *et al.* (1994).

**REFERENCES :**

1. McCarthy, D.D., Petit, G. (eds.), 2004, IERS Conventions (2003), IERS Technical Note No. 32, BKG.
2. Simon, J.-L., Bretagnon, P., Chapront, J., Chapront-Touzé, M., Francou, G & Laskar J., 1994, *Astron.Astrophys.*, **282**, 663-683.
3. Souchay, J., Loysel, B., Kinoshita, H., Folgueira, M., 1999, *Astron.Astrophys.Supp.Ser.* **135**, 111.

---

**iau\_FANE03**      *mean longitude of Neptune, IERS 2003*      **iau\_FANE03**

**CALL :**

D = iau\_FANE03 ( T )

**ACTION :**

Fundamental argument, IERS Conventions (2003): mean longitude of Neptune.

**GIVEN :**

*T*                    d                    TDB, Julian centuries since J2000.0 (Note 1)

**RETURNED** (function value) :

d                    mean longitude of Neptune, radians (Note 2)

**NOTES :**

1. Though *T* is strictly TDB, it is usually more convenient to use TT, which makes no significant difference.
2. The expression used is as adopted in IERS Conventions (2003) and comes from Souchay *et al.* (1999) after Simon *et al.* (1994).

**REFERENCES :**

1. McCarthy, D.D., Petit, G. (eds.), 2004, IERS Conventions (2003), IERS Technical Note No. 32, BKG.
2. Simon, J.-L., Bretagnon, P., Chapront, J., Chapront-Touzé, M., Francou, G & Laskar J., 1994, *Astron.Astrophys.*, **282**, 663-683.
3. Souchay, J., Loysel, B., Kinoshita, H., Folgueira, M., 1999, *Astron.Astrophys.Supp.Ser.* **135**, 111.

---

**iau\_FAOM03**    *mean long. of Moon's asc. node, IERS 2003*    **iau\_FAOM03**

**CALL :**

D = iau\_FAOM03 ( T )

**ACTION :**

Fundamental argument, IERS Conventions (2003): mean longitude of the Moon's ascending node.

**GIVEN :**

*T*            d            TDB, Julian centuries since J2000.0 (Note 1)

**RETURNED** (function value) :

d            mean long. of Moon's asc. node, radians (Note 2)

**NOTES :**

1. Though *T* is strictly TDB, it is usually more convenient to use TT, which makes no significant difference.
2. The expression used is as adopted in IERS Conventions (2003) and is from Simon *et al.* (1994).

**REFERENCES :**

1. McCarthy, D.D., Petit, G. (eds.), 2004, IERS Conventions (2003), IERS Technical Note No. 32, BKG.
2. Simon, J.-L., Bretagnon, P., Chapront, J., Chapront-Touzé, M., Francou, G & Laskar J., 1994, *Astron.Astrophys.*, **282**, 663-683.

---

**iau\_FAPA03**      *general precession in longitude, IERS 2003*      **iau\_FAPA03****CALL :**

D = iau\_FAPA03 ( T )

**ACTION :**

Fundamental argument, IERS Conventions (2003): general accumulated precession in longitude.

**GIVEN :**

*T*                    d                    TDB, Julian centuries since J2000.0 (Note 1)

**RETURNED** (function value) :

                          d                    general precession in longitude, radians (Note 2)

**NOTES :**

1. Though *T* is strictly TDB, it is usually more convenient to use TT, which makes no significant difference.
2. The expression used is as adopted in IERS Conventions (2003). It is taken from Kinoshita & Souchay (1990) and comes originally from Lieske *et al.* (1977).

**REFERENCES :**

1. Kinoshita, H. & Souchay, J., 1990, *Celest.Mech.Dyn.Astron.*, **48**, 187.
2. Lieske, J.H., Lederle, T., Fricke, W. & Morando, B., 1977, *Astron.Astrophys.*, **58**, 1-16.
3. McCarthy, D.D., Petit, G. (eds.), 2004, IERS Conventions (2003), IERS Technical Note No. 32, BKG.

---

**iau\_FASA03**                      *mean longitude of Saturn, IERS 2003*                      **iau\_FASA03**

**CALL :**

D = iau\_FASA03 ( T )

**ACTION :**

Fundamental argument, IERS Conventions (2003): mean longitude of Saturn.

**GIVEN :**

T                      d                      TDB, Julian centuries since J2000.0 (Note 1)

**RETURNED** (function value) :

d                      mean longitude of Saturn, radians (Note 2)

**NOTES :**

1. Though T is strictly TDB, it is usually more convenient to use TT, which makes no significant difference.
2. The expression used is as adopted in IERS Conventions (2003) and comes from Souchay *et al.* (1999) after Simon *et al.* (1994).

**REFERENCES :**

1. McCarthy, D.D., Petit, G. (eds.), 2004, IERS Conventions (2003), IERS Technical Note No. 32, BKG.
2. Simon, J.-L., Bretagnon, P., Chapront, J., Chapront-Touzé, M., Francou, G & Laskar J., 1994, *Astron.Astrophys.*, **282**, 663-683.
3. Souchay, J., Loysel, B., Kinoshita, H., Folgueira, M., 1999, *Astron.Astrophys.Supp.Ser.* **135**, 111.

---

**iau\_FAUR03**      *mean longitude of Uranus, IERS 2003*      **iau\_FAUR03**

**CALL :**

D = iau\_FAUR03 ( T )

**ACTION :**

Fundamental argument, IERS Conventions (2003): mean longitude of Uranus.

**GIVEN :**

T            d            TDB, Julian centuries since J2000.0 (Note 1)

**RETURNED** (function value) :

d            mean longitude of Uranus, radians (Note 2)

**NOTES :**

1. Though T is strictly TDB, it is usually more convenient to use TT, which makes no significant difference.
2. The expression used is as adopted in IERS Conventions (2003) and comes from Souchay *et al.* (1999) after Simon *et al.* (1994).

**REFERENCES :**

1. McCarthy, D.D., Petit, G. (eds.), 2004, IERS Conventions (2003), IERS Technical Note No. 32, BKG.
2. Simon, J.-L., Bretagnon, P., Chapront, J., Chapront-Touzé, M., Francou, G & Laskar J., 1994, *Astron.Astrophys.*, **282**, 663-683.
3. Souchay, J., Loysel, B., Kinoshita, H., Folgueira, M., 1999, *Astron.Astrophys.Supp.Ser.* **135**, 111.

---

**iau\_FAVE03**                      *mean longitude of Venus, IERS 2003*                      **iau\_FAVE03**

**CALL :**

D = iau\_FAVE03 ( T )

**ACTION :**

Fundamental argument, IERS Conventions (2003): mean longitude of Venus.

**GIVEN :**

T                      d                      TDB, Julian centuries since J2000.0 (Note 1)

**RETURNED** (function value) :

d                      mean longitude of Venus, radians (Note 2)

**NOTES :**

1. Though T is strictly TDB, it is usually more convenient to use TT, which makes no significant difference.
2. The expression used is as adopted in IERS Conventions (2003) and comes from Souchay *et al.* (1999) after Simon *et al.* (1994).

**REFERENCES :**

1. McCarthy, D.D., Petit, G. (eds.), 2004, IERS Conventions (2003), IERS Technical Note No. 32, BKG.
2. Simon, J.-L., Bretagnon, P., Chapront, J., Chapront-Touzé, M., Francou, G & Laskar J., 1994, *Astron.Astrophys.*, **282**, 663-683.
3. Souchay, J., Loysel, B., Kinoshita, H., Folgueira, M., 1999, *Astron.Astrophys.Supp.Ser.* **135**, 111.



---

**iau\_FW2M**                      *form rotation matrix from F-W angles*                      **iau\_FW2M**

**CALL :**

CALL iau\_FW2M ( GAMB, PHIB, PSI, EPS, R )

**ACTION :**

Form rotation matrix given the Fukushima-Williams angles.

**GIVEN :**

<i>GAMB</i>	d	F-W angle $\bar{\gamma}$ (radians)
<i>PHIB</i>	d	F-W angle $\bar{\phi}$ (radians)
<i>PSI</i>	d	F-W angle $\psi$ (radians)
<i>EPS</i>	d	F-W angle $\epsilon$ (radians)

**RETURNED :**

<i>R</i>	d(3,3)	rotation matrix
----------	--------	-----------------

**NOTES :**

1. Naming the following points:

e = J2000.0 ecliptic pole,  
p = GCRS pole,  
E = ecliptic pole of date and  
P = CIP,

the four Fukushima-Williams angles are as follows:

$\gamma = \text{epE}$   
 $\phi = \text{pE}$   
 $\psi = \text{pEP}$   
 $\epsilon = \text{EP}$

2. The matrix representing the combined effects of frame bias, precession and nutation is:

$$\mathbf{NPB} = \mathbf{R}_1(-\epsilon) \mathbf{R}_3(-\psi) \mathbf{R}_1(\bar{\phi}) \mathbf{R}_3(\bar{\gamma})$$

3. The present routine can construct three different matrices, depending on which angles are supplied as the arguments **GAMB**, **PHIB**, **PSI** and **EPS**:

- To obtain the **NPB** matrix, first generate the four precession angles known conventionally as  $\bar{\gamma}$ ,  $\bar{\phi}$ ,  $\bar{\psi}$  and  $\epsilon_A$ , then generate the nutation components  $\Delta\psi$  and  $\Delta\epsilon$  and add them to  $\bar{\psi}$  and  $\epsilon_A$ , and finally call the present routine using those four angles as arguments.
- To obtain the **PB** matrix, generate the four precession angles and call the present routine.
- To obtain the **B** matrix, generate the four precession angles for date J2000.0 and call the present routine.

The nutation-only and precession-only matrices can if necessary be obtained by combining these three appropriately.

**REFERENCES :**

1. Capitaine, N. & Wallace, P.T., 2006, *Astron.Astrophys.*, **450**, 855.
2. Hilton, J. *et al.*, 2006, *Celest.Mech.Dyn.Astron.*, **94**, 351.

---

**iau\_FW2XY**      *CIP X, Y given Fukushima-Williams angles*      **iau\_FW2XY**

**CALL :**

CALL iau\_FW2XY ( GAMB, PHIB, PSI, EPS, X, Y )

**ACTION :**

CIP  $X, Y$  given Fukushima-Williams bias-precession-nutation angles.

**GIVEN :**

<i>GAMB</i>	d	F-W angle $\bar{\gamma}$ (radians)
<i>PHIB</i>	d	F-W angle $\bar{\phi}$ (radians)
<i>PSI</i>	d	F-W angle $\psi$ (radians)
<i>EPS</i>	d	F-W angle $\epsilon$ (radians)

**RETURNED :**

$X, Y$	d	CIP unit vector $X, Y$
--------	---	------------------------

**NOTES :**

1. Naming the following points:

e = J2000.0 ecliptic pole,  
 p = GCRS pole,  
 E = ecliptic pole of date and  
 P = CIP,

the four Fukushima-Williams angles are as follows:

$\gamma = epE$   
 $\phi = pE$   
 $\psi = pEP$   
 $\epsilon = EP$

2. The matrix representing the combined effects of frame bias, precession and nutation is:

$$\mathbf{N P B} = \mathbf{R}_1(-\epsilon) \mathbf{R}_3(-\psi) \mathbf{R}_1(\bar{\phi}) \mathbf{R}_3(\bar{\gamma})$$

The returned values  $X, Y$  are elements (3,1) and (3,2) of the matrix. Near J2000.0, they are essentially angles in radians.

**REFERENCE :**

Hilton, J. *et al.*, 2006, *Celest.Mech.Dyn.Astron.*, **94**, 351.

---

**iau\_GMST00**    *Greenwich Mean Sidereal Time, IAU 2000*    **iau\_GMST00**

---

**CALL :**

D = iau\_GMST00 ( UTA, UTB, TTA, TTB )

**ACTION :**

Greenwich Mean Sidereal Time (model consistent with IAU 2000 resolutions).

**GIVEN :**

UTA, UTB    d                    UT1 as a two-part Julian Date (Notes 1,2)

TTA, TTB    d                    TT as a two-part Julian Date (Notes 1,2)

**RETURNED** (function value) :

          d                    Greenwich mean sidereal time (radians)

**NOTES :**

1. The UT1 and TT dates UTA+UTB and TTA+TTB respectively, are both Julian Dates, apportioned in any convenient way between the argument pairs. For example, JD(UT1) = 2450123.7 could be expressed in any of these ways, among others:

UTA	UTB	
2450123.7D0	0D0	(JD method)
2451545.0D0	-1421.3D0	(J2000 method)
2400000.5D0	50123.2D0	(MJD method)
2450123.5D0	0.2D0	(date & time method)

The JD method is the most natural and convenient to use in cases where the loss of several decimal digits of resolution is acceptable (in the case of UT; the TT is not at all critical in this respect). The J2000 and MJD methods are good compromises between resolution and convenience. For UT, the date & time method is best matched to the algorithm that is used by the Earth Rotation Angle routine, called internally: maximum accuracy (or, at least, minimum noise) is delivered when the UTA argument is for 0<sup>h</sup> UT1 on the day in question and the UTB argument lies in the range 0 to 1, or *vice versa*.

2. Both UT1 and TT are required, UT1 to predict the Earth rotation and TT to predict the effects of precession. If UT1 is used for both purposes, errors of order 100 $\mu$ s result.
3. This GMST is compatible with the IAU 2000 resolutions and must be used only in conjunction with other IAU 2000 compatible components such as precession-nutation and equation of the equinoxes.
4. The result is returned in the range 0 to  $2\pi$ .
5. The algorithm is from Capitaine *et al.* (2003) and IERS Conventions 2003.

**REFERENCES :**

1. Capitaine, N., Wallace, P.T. & McCarthy, D.D., 2003, *Astron.Astrophys.*, **406**, 1135-1149.
2. McCarthy, D.D., Petit, G. (eds.), 2004, *IERS Conventions (2003)*, IERS Technical Note No. 32, BKG.

---

**iau\_GMST06**      *Greenwich mean sidereal time, IAU 2006*      **iau\_GMST06**
**CALL :**

D = iau\_GMST06 ( UTA, UTB, TTA, TTB )

**ACTION :**

Greenwich mean sidereal time (consistent with IAU 2006 precession).

**GIVEN :**

*UTA, UTB*    d                      UT1 as a two-part Julian Date (Notes 1,2)  
*TTA, TTB*    d                      TT as a two-part Julian Date (Notes 1,2)

**RETURNED** (function value) :

d                      Greenwich mean sidereal time (radians)

**NOTES :**

1. The UT1 and TT dates UTA+UTB and TTA+TTB respectively, are both Julian Dates, apportioned in any convenient way between the argument pairs. For example,  $JD(UT1) = 2450123.7$  could be expressed in any of these ways, among others:

UTA	UTB	
2450123.7D0	0D0	(JD method)
2451545.0D0	-1421.3D0	(J2000 method)
2400000.5D0	50123.2D0	(MJD method)
2450123.5D0	0.2D0	(date & time method)

The JD method is the most natural and convenient to use in cases where the loss of several decimal digits of resolution is acceptable (in the case of UT; the TT is not at all critical in this respect). The J2000 and MJD methods are good compromises between resolution and convenience. For UT, the date & time method is best matched to the algorithm that is used by the Earth Rotation Angle routine, called internally: maximum accuracy (or, at least, minimum noise) is delivered when the UTA argument is for 0<sup>h</sup> UT1 on the day in question and the UTB argument lies in the range 0 to 1, or *vice versa*.

2. Both UT1 and TT are required, UT1 to predict the Earth rotation and TT to predict the effects of precession. If UT1 is used for both purposes, errors of order 100 $\mu$ s result.
3. This GMST is compatible with the IAU 2006 precession and must not be used with other precession models.
4. The result is returned in the range 0 to  $2\pi$ .

**REFERENCE :**

Capitaine, N., Wallace, P.T. & Chapront, J., 2003, *Astron.Astrophys.* **432**, 355.

---

**iau\_GMST82**    *Greenwich Mean Sidereal Time, IAU 1982*    **iau\_GMST82**

---

**CALL :**

D = iau\_GMST82 ( DJ1, DJ2 )

**ACTION :**

Universal Time to Greenwich Mean Sidereal Time (IAU 1982 model).

**GIVEN :**

*DJ1, DJ2*    d                    UT1 as a two-part Julian Date (see notes)

**RETURNED** (function value) :

d                    Greenwich mean sidereal time (radians)

**NOTES :**

1. The UT1 DJ1+DJ2 is a Julian Date, apportioned in any convenient way between the two arguments. For example, JD(UT1) = 2450123.7 could be expressed in any of these ways, among others:

DJ1	DJ2	
2450123.7D0	0D0	(JD method)
2451545.0D0	-1421.3D0	(J2000 method)
2400000.5D0	50123.2D0	(MJD method)
2450123.5D0	0.2D0	(date & time method)

The JD method is the most natural and convenient to use in cases where the loss of several decimal digits of resolution is acceptable (in the case of UT; the TT is not at all critical in this respect). The J2000 and MJD methods are good compromises between resolution and convenience. For UT, the date & time method is best matched to the algorithm that is used by the Earth Rotation Angle routine, called internally: maximum accuracy (or, at least, minimum noise) is delivered when the DJ1 argument is for 0<sup>h</sup> UT1 on the day in question and the DJ2 argument lies in the range 0 to 1, or *vice versa*.

2. The algorithm is based on the IAU 1982 expression. This is always described as giving the GMST at 0<sup>h</sup> UT1. In fact, it gives the difference between the GMST and the UT1, the steady 4-minutes-per-day drawing-ahead of ST with respect to UT. When whole days are ignored, the expression happens to equal the GMST at 0<sup>h</sup> UT1 each day.
3. In this routine, the entire UT1 (the sum of the two arguments DJ1 and DJ2) is used directly as the argument for the standard formula, the constant term of which is adjusted by 12 hours to take account of the noon phasing of Julian Date. The UT1 is then added, but omitting whole days to conserve accuracy.
4. The result is returned in the range 0 to  $2\pi$ .

**REFERENCES :**

1. Transactions of the International Astronomical Union, XVIII B, 67 (1983).
2. Aoki, S., Guinot B., Kaplan, G.H., Kinoshita, H., McCarthy, D.D. & Seidelmann, P.K., 1982, *Astron.Astrophys.*, **105**, 359-361.

---

**iau\_GST00A** *Greenwich Apparent Sidereal Time, IAU 2000A* **iau\_GST00A**

---

**CALL :**

D = iau\_GST00A ( UTA, UTB, TTA, TTB )

**ACTION :**

Greenwich Apparent Sidereal Time (consistent with IAU 2000 resolutions).

**GIVEN :**

*UTA, UTB* d                    UT1 as a two-part Julian Date (Notes 1,2)  
*TTA, TTB* d                    TT as a two-part Julian Date (Notes 1,2)

**RETURNED** (function value) :

d                    Greenwich apparent sidereal time (radians)

**NOTES :**

1. The UT1 and TT dates UTA+UTB and TTA+TTB respectively, are both Julian Dates, apportioned in any convenient way between the argument pairs. For example,  $JD(UT1) = 2450123.7$  could be expressed in any of these ways, among others:

UTA	UTB	
2450123.7D0	0D0	(JD method)
2451545.0D0	-1421.3D0	(J2000 method)
2400000.5D0	50123.2D0	(MJD method)
2450123.5D0	0.2D0	(date & time method)

- The JD method is the most natural and convenient to use in cases where the loss of several decimal digits of resolution is acceptable (in the case of UT; the TT is not at all critical in this respect). The J2000 and MJD methods are good compromises between resolution and convenience. For UT, the date & time method is best matched to the algorithm that is used by the Earth Rotation Angle routine, called internally: maximum accuracy (or, at least, minimum noise) is delivered when the UTA argument is for 0<sup>h</sup> UT1 on the day in question and the UTB argument lies in the range 0 to 1, or *vice versa*.
2. Both UT1 and TT are required, UT1 to predict the Earth rotation and TT to predict the effects of precession. If UT1 is used for both purposes, errors of order 100 $\mu$ s result.
  3. This GAST is compatible with the IAU 2000 resolutions and must be used only in conjunction with other IAU 2000 compatible components such as precession-nutation.
  4. The result is returned in the range 0 to  $2\pi$ .
  5. The algorithm is from Capitaine *et al.* (2003) and IERS Conventions 2003.

**REFERENCES :**

1. Capitaine, N., Wallace, P.T. & McCarthy, D.D., 2003, *Astron.Astrophys.*, **406**, 1135-1149.
2. McCarthy, D.D., Petit, G. (eds.), 2004, *IERS Conventions (2003)*, IERS Technical Note No. 32, BKG.

---

**iau\_GST00B** *Greenwich Apparent Sidereal Time, IAU 2000B* **iau\_GST00B**

---

**CALL :**

D = iau\_GST00B ( UTA, UTB )

**ACTION :**

Greenwich Apparent Sidereal Time (consistent with IAU 2000 resolutions but using the truncated nutation model IAU 2000B).

**GIVEN :**

*UTA, UTB* d UT1 as a two-part Julian Date (Notes 1,2)

**RETURNED** (function value) :

d Greenwich apparent sidereal time (radians)

**NOTES :**

1. The UT1 date UTA+UTB is a Julian Date, apportioned in any convenient way between the two arguments. For example,  $JD(UT1) = 2450123.7$  could be expressed in any of these ways, among others:

UTA	UTB	
2450123.7D0	0D0	(JD method)
2451545.0D0	-1421.3D0	(J2000 method)
2400000.5D0	50123.2D0	(MJD method)
2450123.5D0	0.2D0	(date & time method)

The JD method is the most natural and convenient to use in cases where the loss of several decimal digits of resolution is acceptable (in the case of UT; the TT is not at all critical in this respect). The J2000 and MJD methods are good compromises between resolution and convenience. For UT, the date & time method is best matched to the algorithm that is used by the Earth Rotation Angle routine, called internally: maximum accuracy (or, at least, minimum noise) is delivered when the UTA argument is for 0<sup>h</sup> UT1 on the day in question and the UTB argument lies in the range 0 to 1, or *vice versa*.

2. The result is compatible with the IAU 2000 resolutions, except that accuracy has been compromised for the sake of speed and convenience in two respects:
  - UT is used instead of TDB (or TT) to compute the precession component of GMST and the equation of the equinoxes. This results in errors of order 0.1 mas at present.
  - The IAU 2000B abridged nutation model (McCarthy & Luzum, 2003) is used, introducing errors of up to 1 mas.
3. This GAST is compatible with the IAU 2000 resolutions and must be used only in conjunction with other IAU 2000 compatible components such as precession-nutation.
4. The result is returned in the range 0 to  $2\pi$ .
5. The algorithm is from Capitaine *et al.* (2003) and IERS Conventions 2003.



**REFERENCES :**

1. Capitaine, N., Wallace, P.T. & McCarthy, D.D., 2003, *Astron.Astrophys.*, **406**, 1135-1149.
2. McCarthy, D.D. & Luzum, B.J., 2003, *Celestial Mechanics & Dynamical Astronomy*, **85**, 37-49.
3. McCarthy, D.D., Petit, G. (eds.), 2004, *IERS Conventions (2003)*, IERS Technical Note No. 32, BKG.

---

**iau\_GST06**                      *GAST, IAU 2006, given NPB matrix*                      **iau\_GST06**

**CALL :**

D = iau\_GST06 ( UTA, UTB, TTA, TTB, RNPB )

**ACTION :**

Greenwich apparent sidereal time, IAU 2006, given the NPB matrix.

**GIVEN :**

<i>UTA, UTB</i>	d	UT1 as a two-part Julian Date (Notes 1,2)
<i>TTA, TTB</i>	d	TT as a two-part Julian Date (Notes 1,2)
<i>RNPB</i>	d(3,3)	nututation $\times$ precession $\times$ bias matrix

**RETURNED** (function value) :

d                      Greenwich apparent sidereal time (radians)

**NOTES :**

1. The UT1 and TT dates UTA+UTB and TTA+TTB respectively, are both Julian Dates, apportioned in any convenient way between the argument pairs. For example, JD(UT1) = 2450123.7 could be expressed in any of these ways, among others:

UTA	UTB	
2450123.7D0	0D0	(JD method)
2451545.0D0	-1421.3D0	(J2000 method)
2400000.5D0	50123.2D0	(MJD method)
2450123.5D0	0.2D0	(date & time method)

The JD method is the most natural and convenient to use in cases where the loss of several decimal digits of resolution is acceptable (in the case of UT; the TT is not at all critical in this respect). The J2000 and MJD methods are good compromises between resolution and convenience. For UT, the date & time method is best matched to the algorithm that is used by the Earth Rotation Angle routine, called internally: maximum accuracy (or, at least, minimum noise) is delivered when the UTA argument is for 0<sup>h</sup> UT1 on the day in question and the UTB argument lies in the range 0 to 1, or *vice versa*.

2. Both UT1 and TT are required, UT1 to predict the Earth rotation and TT to predict the effects of precession-nutation. If UT1 is used for both purposes, errors of order 100 $\mu$ as result.
3. Although the routine uses the IAU 2006 series for  $s + XY/2$ , it is otherwise independent of the precession-nutation model and can in practice be used with any equinox-based NPB matrix.
4. The result is returned in the range 0 to  $2\pi$ .

**REFERENCE :**

Wallace, P.T. & Capitaine, N., 2006, *Astron.Astrophys.*, **459**, 981-985.

---

**iau\_GST06A** *Greenwich Appt. Sidereal Time, IAU 2006/2000A* **iau\_GST06A**

---

**CALL :**

D = iau\_GST06A ( UTA, UTB, TTA, TTB )

**ACTION :**

Greenwich apparent sidereal time (consistent with IAU 2000 and 2006 resolutions).

**GIVEN :**

*UTA, UTB* d                    UT1 as a two-part Julian Date (Notes 1,2)  
*TTA, TTB* d                    TT as a two-part Julian Date (Notes 1,2)

**RETURNED** (function value) :

d                    Greenwich apparent sidereal time (radians)

**NOTES :**

1. The UT1 and TT dates UTA+UTB and TTA+TTB respectively, are both Julian Dates, apportioned in any convenient way between the argument pairs. For example,  $JD(UT1) = 2450123.7$  could be expressed in any of these ways, among others:

UTA	UTB	
2450123.7D0	0D0	(JD method)
2451545.0D0	-1421.3D0	(J2000 method)
2400000.5D0	50123.2D0	(MJD method)
2450123.5D0	0.2D0	(date & time method)

- The JD method is the most natural and convenient to use in cases where the loss of several decimal digits of resolution is acceptable (in the case of UT; the TT is not at all critical in this respect). The J2000 and MJD methods are good compromises between resolution and convenience. For UT, the date & time method is best matched to the algorithm that is used by the Earth Rotation Angle routine, called internally: maximum accuracy (or, at least, minimum noise) is delivered when the UTA argument is for 0<sup>h</sup> UT1 on the day in question and the UTB argument lies in the range 0 to 1, or *vice versa*.
2. Both UT1 and TT are required, UT1 to predict the Earth rotation and TT to predict the effects of precession. If UT1 is used for both purposes, errors of order 100 $\mu$ s result.
  3. This GAST is compatible with the IAU 2000/2006 resolutions and must be used only in conjunction with IAU 2006 precession and IAU 2000A nutation.
  4. The result is returned in the range 0 to  $2\pi$ .

**REFERENCE :**

Wallace, P.T. & Capitaine, N., 2006, *Astron.Astrophys.*, **459**, 981-985.





---

**iau\_NUM00A**                      *nututation matrix, IAU 2000A*                      **iau\_NUM00A**

**CALL :**

CALL iau\_NUM00A ( DATE1, DATE2, RMATN )

**ACTION :**

Form the matrix of nutation for a given date, IAU 2000A model.

**GIVEN :**

*DATE1*      d                      TT as a two-part...  
*DATE2*      d                      ... Julian Date (Note 1)

**RETURNED :**

*RMATN*      d(3,3)                      nututation matrix **N**

**NOTES :**

1. The TT date DATE1+DATE2 is a Julian Date, apportioned in any convenient way between the arguments DATE1 and DATE2. For example, JD(TT) = 2450123.7 could be expressed in any of these ways, among others:

DATE1	DATE2	
2450123.7D0	0D0	(JD method)
2451545.0D0	-1421.3D0	(J2000 method)
2400000.5D0	50123.2D0	(MJD method)
2450123.5D0	0.2D0	(date & time method)

The JD method is the most natural and convenient to use in cases where the loss of several decimal digits of resolution is acceptable. The J2000 method is best matched to the way the argument is handled internally and will deliver the optimum resolution. The MJD method and the date & time methods are both good compromises between resolution and convenience.

2. The matrix operates in the sense

$$\mathbf{v}_{\text{true}} = \mathbf{N} \mathbf{v}_{\text{mean}} ,$$

where the p-vector  $\mathbf{v}_{\text{true}}$  is with respect to the true equatorial triad of date and the p-vector  $\mathbf{v}_{\text{mean}}$  is with respect to the mean equatorial triad of date.

3. A faster, but slightly less accurate, result (about 1 mas) can be obtained by using instead the iau\_NUM00B routine.

**REFERENCE :**

Seidelmann, P.K. (Ed.) (1992), *Explanatory Supplement to the Astronomical Almanac*, University Science Books, Section 3.222-3 (p114).

---

**iau\_NUM00B**                      *nutaton matrix, IAU 2000B*                      **iau\_NUM00B**

**CALL :**

CALL iau\_NUM00B ( DATE1, DATE2, RMATN )

**ACTION :**

Form the matrix of nutation for a given date, IAU 2000B model.

**GIVEN :**

*DATE1*      d                      TT as a two-part...  
*DATE2*      d                      ... Julian Date (Note 1)

**RETURNED :**

*RMATN*      d(3,3)                      nutation matrix **N**

**NOTES :**

1. The TT date DATE1+DATE2 is a Julian Date, apportioned in any convenient way between the arguments DATE1 and DATE2. For example, JD(TT) = 2450123.7 could be expressed in any of these ways, among others:

DATE1	DATE2	
2450123.7D0	0D0	(JD method)
2451545.0D0	-1421.3D0	(J2000 method)
2400000.5D0	50123.2D0	(MJD method)
2450123.5D0	0.2D0	(date & time method)

The JD method is the most natural and convenient to use in cases where the loss of several decimal digits of resolution is acceptable. The J2000 method is best matched to the way the argument is handled internally and will deliver the optimum resolution. The MJD method and the date & time methods are both good compromises between resolution and convenience.

2. The matrix operates in the sense

$$\mathbf{v}_{\text{true}} = \mathbf{N} \mathbf{v}_{\text{mean}} ,$$

where the p-vector  $\mathbf{v}_{\text{true}}$  is with respect to the true equatorial triad of date and the p-vector  $\mathbf{v}_{\text{mean}}$  is with respect to the mean equatorial triad of date.

3. The present routine is faster, but slightly less accurate (about 1 mas), than the iau\_NUM00A routine.

**REFERENCE :**

Seidelmann, P.K. (Ed.) (1992), *Explanatory Supplement to the Astronomical Almanac*, University Science Books, Section 3.222-3 (p114).

---

**iau\_NUM06A**                    *nutaton matrix, IAU 2006/2000A*                    **iau\_NUM06A**

**CALL :**

CALL iau\_NUM06A ( DATE1, DATE2, RMATN )

**ACTION :**

Form the matrix of nutation for a given date, IAU 2006/2000A model.

**GIVEN :**

*DATE1*     d                    TT as a two-part...  
*DATE2*     d                    ... Julian Date (Note 1)

**RETURNED :**

*RMATN*    d(3,3)                nutation matrix **N**

**NOTES :**

1. The TT date *DATE1*+*DATE2* is a Julian Date, apportioned in any convenient way between the arguments *DATE1* and *DATE2*. For example,  $JD(TT) = 2450123.7$  could be expressed in any of these ways, among others:

<i>DATE1</i>	<i>DATE2</i>	
2450123.7D0	0D0	(JD method)
2451545.0D0	-1421.3D0	(J2000 method)
2400000.5D0	50123.2D0	(MJD method)
2450123.5D0	0.2D0	(date & time method)

The JD method is the most natural and convenient to use in cases where the loss of several decimal digits of resolution is acceptable. The J2000 method is best matched to the way the argument is handled internally and will deliver the optimum resolution. The MJD method and the date & time methods are both good compromises between resolution and convenience.

2. The matrix operates in the sense

$$\mathbf{v}_{\text{true}} = \mathbf{N} \mathbf{v}_{\text{mean}} ,$$

where the p-vector  $\mathbf{v}_{\text{true}}$  is with respect to the true equatorial triad of date and the p-vector  $\mathbf{v}_{\text{mean}}$  is with respect to the mean equatorial triad of date.

**REFERENCES :**

1. Capitaine, N., Wallace, P.T. & Chapront, J., 2003, *Astron.Astrophys.* **432**, 355.
2. Wallace, P.T. & Capitaine, N., 2006, *Astron.Astrophys.*, **459**, 981-985.



---

**iau\_NUMAT**                      *nututation matrix from components*                      **iau\_NUMAT**

---

**CALL :**

CALL iau\_NUMAT ( EPSA, DPSI, DEPS, RMATN )

**ACTION :**

Form the matrix of nutation, given  $\Delta\psi$ ,  $\Delta\epsilon$  and  $\epsilon_A$ .

**GIVEN :**

<i>EPSA</i>	d	mean obliquity of date $\epsilon_A$ (radians, Note 1)
<i>DPSI</i>	d	nutation in longitude $\Delta\psi$ (radians, Note 2)
<i>DEPS</i>	d	nutation in obliquity $\Delta\epsilon$ (radians, Note 2)

**RETURNED :**

<i>RMATN</i>	d(3,3)	nutation matrix (Note 3)
--------------	--------	--------------------------

**NOTES :**

1. The supplied mean obliquity **EPSA**, must be consistent with the precession-nutation models from which **DPSI** and **DEPS** were obtained.
2. The caller is responsible for providing the nutation components; they are in longitude and obliquity, in radians and are with respect to the equinox and ecliptic of date.
3. The matrix operates in the sense

$$\mathbf{v}_{\text{true}} = \mathbf{N} \mathbf{v}_{\text{mean}} ,$$

where the p-vector  $\mathbf{v}_{\text{true}}$  is with respect to the true equatorial triad of date and the p-vector  $\mathbf{v}_{\text{mean}}$  is with respect to the mean equatorial triad of date.

**REFERENCE :**

Seidelmann, P.K. (Ed.) (1992), *Explanatory Supplement to the Astronomical Almanac*, University Science Books, Section 3.222-3 (p114).

---

<b>iau_NUT00A</b>	<i>nutaton, IAU 2000A</i>	<b>iau_NUT00A</b>
-------------------	---------------------------	-------------------

**CALL :**

```
CALL iau_NUT00A ( DATE1, DATE2, DPSI, DEPS )
```

**ACTION :**

Nutation, IAU 2000A model (MHB2000 luni-solar and planetary nutation with free core nutation omitted).

**GIVEN :**

<i>DATE1</i>	d	TT as a two-part...
<i>DATE2</i>	d	... Julian Date (Note 1)

**RETURNED :**

<i>DPSI</i>	d	nutaton in longitude $\Delta\psi$ (radians, Note 2)
<i>DEPS</i>	d	nutaton in obliquity $\Delta\epsilon$ (radians, Note 2)

**NOTES :**

- The TT date DATE1+DATE2 is a Julian Date, apportioned in any convenient way between the arguments DATE1 and DATE2. For example,  $JD(TT) = 2450123.7$  could be expressed in any of these ways, among others:

DATE1	DATE2	
2450123.7D0	0D0	(JD method)
2451545.0D0	-1421.3D0	(J2000 method)
2400000.5D0	50123.2D0	(MJD method)
2450123.5D0	0.2D0	(date & time method)

The JD method is the most natural and convenient to use in cases where the loss of several decimal digits of resolution is acceptable. The J2000 method is best matched to the way the argument is handled internally and will deliver the optimum resolution. The MJD method and the date & time methods are both good compromises between resolution and convenience.

- The nutation components in longitude and obliquity are in radians and with respect to the equinox and ecliptic of date. The obliquity at J2000.0 is assumed to be the Lieske *et al.* (1977) value of 84381".448.

Both the luni-solar and planetary nutations are included. The latter are due to direct planetary nutations and the perturbations of the lunar and terrestrial orbits.

- The routine computes the MHB2000 nutation series with the associated corrections for planetary nutations. It is an implementation of the nutation part of the IAU 2000A precession- nutation model, formally adopted by the IAU General Assembly in 2000, namely MHB2000 (Mathews *et al.* 2002), but with the free core nutation (FCN – see Note 4) omitted.

4. The full MHB2000 model also contains contributions to the nutations in longitude and obliquity due to the free-excitation of the free-core-nutation during the period 1979-2000. These FCN terms, which are time-dependent and unpredictable, are **not** included in the present routine and, if required, must be independently computed. With the FCN corrections included, the present routine delivers a pole which is at current epochs accurate to a few hundred microarcseconds. The omission of FCN introduces further errors of about that size.
5. The present routine provides classical nutation. The MHB2000 algorithm, from which it is adapted, deals also with (i) the offsets between the GCRS and mean poles and (ii) the adjustments in longitude and obliquity due to the changed precession rates. These additional topics, namely frame bias and precession adjustments, are supported by the SOFA routines `iau_BI00` and `iau_PR00`.
6. The MHB2000 algorithm also provides “total” nutations, comprising the arithmetic sum of the frame bias, precession adjustments, luni-solar nutation and planetary nutation. These total nutations can be used in combination with an existing IAU 1976 precession implementation, such as `iau_PMAT76`, to deliver GCRS-to-true predictions of sub-mas accuracy at current epochs. However, there are three shortcomings in the MHB2000 model that must be taken into account if more accurate or definitive results are required (see Wallace 2002):
  - (a) The MHB2000 total nutations are simply arithmetic sums, yet in reality the various components are successive Euler rotations. This slight lack of rigor leads to cross terms that exceed 1 mas after a century. The rigorous procedure is to form the GCRS-to-true rotation matrix by applying the bias, precession and nutation in that order.
  - (b) Although the MHB2000 precession adjustments ( $\Delta\psi, \Delta\epsilon$ ) are stated to be with respect to Lieske *et al.* (1977), the MHB2000 model does not specify which set of Euler angles are to be used and how the adjustments are to be applied. The most literal and straightforward procedure is to adopt the four-rotation

$$\mathbf{P} = \mathbf{R}_3(\chi_A) \mathbf{R}_1(-\omega_A) \mathbf{R}_3(-\psi_A) \mathbf{R}_1(\epsilon_0)$$

option, and to add  $\Delta\psi$  to  $\psi_A$  and  $\Delta\epsilon$  to both  $\omega_A$  and  $\epsilon_A$ .

- (c) The MHB2000 model predates the determination by Chapront *et al.* (2002) of a 14.6 mas displacement between the J2000.0 mean equinox and the origin of the ICRS frame. It should, however, be noted that neglecting this displacement when calculating star coordinates does not lead to a 14.6 mas change in right ascension, only a small second-order distortion in the pattern of the precession-nutation effect.

For these reasons, the SOFA routines do not generate the “total nutations” directly, though they can of course easily be generated by calling `iau_BI00`, `iau_PR00` and the present routine and adding the results.

7. The MHB2000 model contains 41 instances where the same frequency appears multiple times, of which 38 are duplicates and three are triplicates. To keep the present code close to the original MHB algorithm, this small inefficiency has not been corrected.

**REFERENCES :**

1. Chapront, J., Chapront-Touzé, M. & Francou, G., 2002, *Astron.Astrophys.*, **387**, 700.
2. Lieske, J.H., Lederle, T., Fricke, W. & Morando, B., 1977, *Astron.Astrophys.*, **58**, 1-16.
3. Mathews, P.M., Herring, T.A., Buffet, B.A., 2002, *J.Geophys.Res.*, **107**, B4. The MHB2000 code itself was obtained on 2002 September 9 from <ftp://maia.usno.navy.mil/conv2000/chapter5/IAU2000A>.
4. Simon, J.-L., Bretagnon, P., Chapront, J., Chapront-Touzé, M., Francou, G & Laskar J., 1994, *Astron.Astrophys.*, **282**, 663-683.
5. Souchay, J., Loysel, B., Kinoshita, H., Folgueira, M., 1999, *Astron.Astrophys.Supp.Ser.* **135**, 111.
6. Wallace, P.T., 2002, *Software for Implementing the IAU 2000 Resolutions*, in IERS Workshop 5.1.

---

<b>iau_NUT00B</b>	<i>nutaton, IAU 2000B</i>	<b>iau_NUT00B</b>
-------------------	---------------------------	-------------------

---

**CALL :**

CALL iau\_NUT00B ( DATE1, DATE2, DPSI, DEPS )

**ACTION :**

Nutation, IAU 2000B model.

**GIVEN :**

<i>DATE1</i>	d	TT as a two-part...
<i>DATE2</i>	d	... Julian Date (Note 1)

**RETURNED :**

<i>DPSI</i>	d	nutaton in longitude $\Delta\psi$ (radians, Note 2)
<i>DEPS</i>	d	nutaton in obliquity $\Delta\epsilon$ (radians, Note 2)

**NOTES :**

1. The TT date DATE1+DATE2 is a Julian Date, apportioned in any convenient way between the arguments DATE1 and DATE2. For example, JD(TT) = 2450123.7 could be expressed in any of these ways, among others:

DATE1	DATE2	
2450123.7D0	0D0	(JD method)
2451545.0D0	-1421.3D0	(J2000 method)
2400000.5D0	50123.2D0	(MJD method)
2450123.5D0	0.2D0	(date & time method)

The JD method is the most natural and convenient to use in cases where the loss of several decimal digits of resolution is acceptable. The J2000 method is best matched to the way the argument is handled internally and will deliver the optimum resolution. The MJD method and the date & time methods are both good compromises between resolution and convenience.

2. The nutation components in longitude and obliquity are in radians and with respect to the equinox and ecliptic of date. The obliquity at J2000.0 is assumed to be the Lieske *et al.* (1977) value of 84381".448. (The errors that result from using this routine with the IAU 2006 value of 84381".406 can be neglected.)

The nutation model consists only of luni-solar terms, but includes also a fixed offset which compensates for certain long-period planetary terms (Note 7).

3. This routine is an implementation of the IAU 2000B abridged nutation model formally adopted by the IAU General Assembly in 2000. The routine computes the MHB\_2000\_SHORT luni-solar nutation series (Luzum 2001), but without the associated corrections for the precession rate adjustments and the offset between the GCRS and J2000.0 mean poles.

4. The full IAU 2000A (MHB2000) nutation model contains nearly 1400 terms. The IAU 2000B model (McCarthy & Luzum 2003) contains only 77 terms, plus additional simplifications, yet still delivers results of 1 mas accuracy at present epochs. This combination of accuracy and size makes the IAU 2000B abridged nutation model suitable for most practical applications.

The routine delivers a pole accurate to 1 mas from 1900 to 2100 (usually better than 1 mas, very occasionally just outside 1 mas). The full IAU 2000A model, which is implemented in the routine `iau_NUT00A` (*q.v.*), delivers considerably greater accuracy at current epochs; however, to realize this improved accuracy, corrections for the essentially unpredictable free-core-nutation (FCN) must also be included.

5. The present routine provides classical nutation. The MHB2000 algorithm, from which it is adapted, deals also with (i) the offsets between the GCRS and mean poles and (ii) the adjustments in longitude and obliquity due to the changed precession rates. These additional topics, namely frame bias and precession adjustments, are supported by the SOFA routines `iau_BI00` and `iau_PR00`.
6. The `MHB_2000_SHORT` algorithm also provides “total” nutations, comprising the arithmetic sum of the frame bias, precession adjustments, and nutation (luni-solar + planetary). These total nutations can be used in combination with an existing IAU 1976 precession implementation, such as `iau_PMAT76`, to deliver GCRS-to-true predictions of milliarcsecond accuracy at current epochs. However, for symmetry with the `iau_NUT00A` routine (*q.v.* for the reasons), the SOFA routines do not generate the “total nutations” directly. Should they be required, they could of course easily be generated by calling `iau_BI00`, `iau_PR00` and the present routine and adding the results.
7. The IAU 2000B model includes “planetary bias” terms that are fixed in size but compensate for long-period nutations. The amplitudes quoted in McCarthy & Luzum (2003), namely  $\Delta\psi = -1.5835$  mas and  $\Delta\epsilon = +1.6339$  mas, are optimized for the “total nutations” method described in Note 6. The Luzum (2001) values used in this SOFA implementation, namely  $-0.135$  mas and  $+0.388$  mas, are optimized for the “rigorous” method, where frame bias, precession and nutation are applied separately and in that order. During the interval 1995-2050, the SOFA implementation delivers a maximum error of 1.001 mas (not including FCN).

## REFERENCES :

1. Lieske, J.H., Lederle, T., Fricke, W., Morando, B., 1977, *Astron.Astrophys.*, **58**, 1-2, 1-16.
2. Luzum, B., private communication, 2001 (Fortran code `MHB_2000_SHORT`).
3. McCarthy, D.D. & Luzum, B.J., 2003, *Celestial Mechanics & Dynamical Astronomy*, **85**, 37-49.
4. Simon, J.-L., Bretagnon, P., Chapront, J., Chapront-Touzé, M., Francou, G & Laskar J., 1994, *Astron.Astrophys.*, **282**, 663-683.

---

<b>iau_NUT06A</b>	<i>nutaton, IAU 2006/2000A</i>	<b>iau_NUT06A</b>
-------------------	--------------------------------	-------------------

**CALL :**

CALL iau\_NUT06A ( DATE1, DATE2, DPSI, DEPS )

**ACTION :**

IAU 2000A nutation with adjustments to match the IAU 2006 precession.

**GIVEN :**

<i>DATE1</i>	d	TT as a two-part...
<i>DATE2</i>	d	... Julian Date (Note 1)

**RETURNED :**

<i>DPSI</i>	d	nutation in longitude $\Delta\psi$ (radians, Note 2)
<i>DEPS</i>	d	nutation in obliquity $\Delta\epsilon$ (radians, Note 2)

**NOTES :**

1. The TT date DATE1+DATE2 is a Julian Date, apportioned in any convenient way between the arguments DATE1 and DATE2. For example,  $JD(TT) = 2450123.7$  could be expressed in any of these ways, among others:

DATE1	DATE2	
2450123.7D0	0D0	(JD method)
2451545.0D0	-1421.3D0	(J2000 method)
2400000.5D0	50123.2D0	(MJD method)
2450123.5D0	0.2D0	(date & time method)

- The JD method is the most natural and convenient to use in cases where the loss of several decimal digits of resolution is acceptable. The J2000 method is best matched to the way the argument is handled internally and will deliver the optimum resolution. The MJD method and the date & time methods are both good compromises between resolution and convenience.
2. The nutation components in longitude and obliquity are in radians and with respect to the mean equinox and ecliptic of date, IAU 2006 precession model (Hilton *et al.*, 2006, Capitaine *et al.*, 2005)
  3. The routine first computes the IAU 2000A nutation, then applies adjustments for (i) the consequences of the change in obliquity from the IAU 1980 ecliptic to the IAU 2006 ecliptic and (ii) the secular variation in the Earth's dynamical form factor J2.
  4. The present routine provides classical nutation, complementing the IAU 2000 frame bias and IAU 2006 precession. It delivers a pole which is at current epochs accurate to a few tens of microarcseconds, apart from the free core nutation.

**REFERENCES :**

1. Chapront, J., Chapront-Touzé, M. & Francou, G., 2002, *Astron.Astrophys.*, **387**, 700.
2. Lieske, J.H., Lederle, T., Fricke, W. & Morando, B., 1977, *Astron.Astrophys.*, **58**, 1-16.
3. Mathews, P.M., Herring, T.A., Buffet, B.A., 2002, *J.Geophys.Res.*, **107**, B4. The MHB2000 code itself was obtained on 2002 September 9 from <ftp://maia.usno.navy.mil/conv2000/chapter5/IAU2000A>.
4. Simon, J.-L., Bretagnon, P., Chapront, J., Chapront-Touzé, M., Francou, G & Laskar J., 1994, *Astron.Astrophys.*, **282**, 663-683.
5. Souchay, J., Loysel, B., Kinoshita, H., Folgueira, M., 1999, *Astron.Astrophys.Supp.Ser.* **135**, 111.
6. Wallace, P.T., 2002, *Software for Implementing the IAU 2000 Resolutions*, in IERS Workshop 5.1.



---

**iau\_NUT80***nutaton, IAU 1980***iau\_NUT80****CALL :**

CALL iau\_NUT80 ( DATE1, DATE2, DPSI, DEPS )

**ACTION :**

Nutation, IAU 1980 model.

**GIVEN :**

<i>DATE1</i>	d	TT as a two-part...
<i>DATE2</i>	d	... Julian Date (Note 1)

**RETURNED :**

<i>DPSI</i>	d	nutaton in longitude $\Delta\psi$ (radians, Note 2)
<i>DEPS</i>	d	nutaton in obliquity $\Delta\epsilon$ (radians, Note 2)

**NOTES :**

1. The TT date DATE1+DATE2 is a Julian Date, apportioned in any convenient way between the arguments DATE1 and DATE2. For example,  $JD(TT) = 2450123.7$  could be expressed in any of these ways, among others:

DATE1	DATE2	
2450123.7D0	0D0	(JD method)
2451545.0D0	-1421.3D0	(J2000 method)
2400000.5D0	50123.2D0	(MJD method)
2450123.5D0	0.2D0	(date & time method)

The JD method is the most natural and convenient to use in cases where the loss of several decimal digits of resolution is acceptable. The J2000 method is best matched to the way the argument is handled internally and will deliver the optimum resolution. The MJD method and the date & time methods are both good compromises between resolution and convenience.

2. The nutation components are with respect to the ecliptic of date.

**REFERENCE :**

Seidelmann, P.K. (Ed.) (1992), *Explanatory Supplement to the Astronomical Almanac*, University Science Books, Section 3.222 (p111).

---

**iau\_NUTM80**                      *nutaton matrix, IAU 1980*                      **iau\_NUTM80**

**CALL :**

CALL iau\_NUTM80 ( DATE1, DATE2, RMATN )

**ACTION :**

Form the matrix of nutation for a given date, IAU 1980 model.

**GIVEN :**

*DATE1*      d                      TT as a two-part...  
*DATE2*      d                      ... Julian Date (Note 1)

**RETURNED :**

*RMATN*      d(3,3)                      nutation matrix **N**

**NOTES :**

1. The TT date DATE1+DATE2 is a Julian Date, apportioned in any convenient way between the arguments DATE1 and DATE2. For example,  $JD(TT) = 2450123.7$  could be expressed in any of these ways, among others:

DATE1	DATE2	
2450123.7D0	0D0	(JD method)
2451545.0D0	-1421.3D0	(J2000 method)
2400000.5D0	50123.2D0	(MJD method)
2450123.5D0	0.2D0	(date & time method)

The JD method is the most natural and convenient to use in cases where the loss of several decimal digits of resolution is acceptable. The J2000 method is best matched to the way the argument is handled internally and will deliver the optimum resolution. The MJD method and the date & time methods are both good compromises between resolution and convenience.

2. The matrix operates in the sense

$$\mathbf{v}_{\text{true}} = \mathbf{N} \mathbf{v}_{\text{mean}} ,$$

where the p-vector  $\mathbf{v}_{\text{true}}$  is with respect to the true equatorial triad of date and the p-vector  $\mathbf{v}_{\text{mean}}$  is with respect to the mean equatorial triad of date.

---

**iau\_OBL06***mean obliquity, IAU 2006***iau\_OBL06****CALL :**

D = iau\_OBL06 ( DATE1, DATE2 )

**ACTION :**

Mean obliquity of the ecliptic, IAU 2006 precession model.

**GIVEN :**

<i>DATE1</i>	d	TT as a two-part...
<i>DATE2</i>	d	... Julian Date (Note 1)

**RETURNED** (function value) :

d	obliquity of the ecliptic (radians, Note 2)
---	---

**NOTES :**

1. The TT date DATE1+DATE2 is a Julian Date, apportioned in any convenient way between the arguments DATE1 and DATE2. For example, JD(TT) = 2450123.7 could be expressed in any of these ways, among others:

DATE1	DATE2	
2450123.7D0	0D0	(JD method)
2451545.0D0	-1421.3D0	(J2000 method)
2400000.5D0	50123.2D0	(MJD method)
2450123.5D0	0.2D0	(date & time method)

The JD method is the most natural and convenient to use in cases where the loss of several decimal digits of resolution is acceptable. The J2000 method is best matched to the way the argument is handled internally and will deliver the optimum resolution. The MJD method and the date & time methods are both good compromises between resolution and convenience.

2. The result is the angle between the ecliptic and mean equator of date DATE1+DATE2.

**REFERENCE :**Hilton, J. *et al.*, 2006, *Celest.Mech.Dyn.Astron.*, **94**, 351.

---

<b>iau_OBL80</b>	<i>mean obliquity, IAU 1980</i>	<b>iau_OBL80</b>
------------------	---------------------------------	------------------

**CALL :**

D = iau\_OBL80 ( DATE1, DATE2 )

**ACTION :**

Mean obliquity of the ecliptic, IAU 1980 precession model.

**GIVEN :**

<i>DATE1</i>	d	TT as a two-part...
<i>DATE2</i>	d	... Julian Date (Note 1)

**RETURNED** (function value) :

d	obliquity of the ecliptic (radians, Note 2)
---	---

**NOTES :**

1. The TT date DATE1+DATE2 is a Julian Date, apportioned in any convenient way between the arguments DATE1 and DATE2. For example, JD(TT) = 2450123.7 could be expressed in any of these ways, among others:

DATE1	DATE2	
2450123.7D0	0D0	(JD method)
2451545.0D0	-1421.3D0	(J2000 method)
2400000.5D0	50123.2D0	(MJD method)
2450123.5D0	0.2D0	(date & time method)

The JD method is the most natural and convenient to use in cases where the loss of several decimal digits of resolution is acceptable. The J2000 method is best matched to the way the argument is handled internally and will deliver the optimum resolution. The MJD method and the date & time methods are both good compromises between resolution and convenience.

2. The result is the angle between the ecliptic and mean equator of date DATE1+DATE2.

**REFERENCE :**

Seidelmann, P.K. (Ed.) (1992), *Explanatory Supplement to the Astronomical Almanac*, University Science Books, Section 3.222-3 (p114).

---

**iau\_P06E**                      *precession angles, IAU 2006, equinox based*                      **iau\_P06E**

---

**CALL :**

CALL iau\_P06E ( DATE1, DATE2, EPS0, PSIA, OMA, BPA, BQA, PIA, BPIA, EPSA,  
 CHIA, ZA, ZETAA, THETAA, PA, GAM, PHI, PSI )

**ACTION :**

Precession angles, IAU 2006, equinox based.

**GIVEN :**

*DATE1*     d                      TT as a two-part...  
*DATE2*     d                      ... Julian Date (Note 1)

**RETURNED** (see Note 2) :

<i>EPS0</i>	d	$\epsilon_0$
<i>PSIA</i>	d	$\psi_A$
<i>OMA</i>	d	$\omega_A$
<i>BPA</i>	d	$P_A$
<i>BQA</i>	d	$Q_A$
<i>PIA</i>	d	$\pi_A$
<i>BPIA</i>	d	$\Pi_A$
<i>EPSA</i>	d	$\epsilon_A$
<i>CHIA</i>	d	$\chi_A$
<i>ZA</i>	d	$z_A$
<i>ZETAA</i>	d	$\zeta_A$
<i>THETAA</i>	d	$\theta_A$
<i>PA</i>	d	$p_A$
<i>GAM</i>	d	$\gamma_{J2000}$
<i>PHI</i>	d	$\phi_{J2000}$
<i>PSI</i>	d	$\psi_{J2000}$

**NOTES :**

1. The TT date DATE1+DATE2 is a Julian Date, apportioned in any convenient way between the arguments DATE1 and DATE2. For example,  $JD(TT) = 2450123.7$  could be expressed in any of these ways, among others:

DATE1	DATE2	
2450123.7D0	0D0	(JD method)
2451545.0D0	-1421.3D0	(J2000 method)
2400000.5D0	50123.2D0	(MJD method)
2450123.5D0	0.2D0	(date & time method)

The JD method is the most natural and convenient to use in cases where the loss of several decimal digits of resolution is acceptable. The J2000 method is best matched to the way the argument is handled internally and will deliver the optimum resolution. The MJD method and the date & time methods are both good compromises between resolution and convenience.

2. This routine returns the set of equinox based angles for the Capitaine *et al.* “P03” precession theory, adopted by the IAU in 2006. The angles are set out in Table 1 of Hilton *et al.* (2006):

EPSO	$\epsilon_0$	obliquity at J2000.0
PSIA	$\psi_A$	luni-solar precession
OMA	$\omega_A$	inclination of equator wrt J2000.0 ecliptic
BPA	$P_A$	ecliptic pole $x$ , J2000.0 ecliptic triad
BQA	$Q_A$	ecliptic pole $-y$ , J2000.0 ecliptic triad
PIA	$\pi_A$	angle between moving and J2000.0 ecliptics
BPIA	$\Pi_A$	longitude of ascending node of the ecliptic
EPSA	$\epsilon_A$	obliquity of the ecliptic
CHIA	$\chi_A$	planetary precession
ZA	$z_A$	equatorial precession: $-3^{\text{rd}}$ 323 Euler angle
ZETAA	$\zeta_A$	equatorial precession: $-1^{\text{st}}$ 323 Euler angle
THETAA	$\theta_A$	equatorial precession: $2^{\text{nd}}$ 323 Euler angle
PA	$p_A$	general precession ( <i>n.b.</i> see below)
GAM	$\gamma_{J2000}$	J2000.0 RA difference of ecliptic poles
PHI	$\phi_{J2000}$	J2000.0 codeclination of ecliptic pole
PSI	$\psi_{J2000}$	longitude difference of equator poles, J2000.0

The returned values are all radians.

Note that the  $t^5$  coefficient in the series for  $p_A$  from Capitaine *et al.* (2003) is incorrectly signed in Hilton *et al.* (2006).

3. Hilton *et al.* (2006) Table 1 also contains angles that depend on models distinct from the P03 precession theory itself, namely the IAU 2000A frame bias and nutation. The quoted polynomials are used in other SOFA routines:
- `iau_XY06` contains the polynomial parts of the  $X$  and  $Y$  series.
  - `iau_S06` contains the polynomial part of the  $s + XY/2$  series.
  - `iau_PFW06` implements the series for the Fukushima-Williams angles that are with respect to the GCRS pole (*i.e.* the variants that include frame bias).
4. The IAU resolution stipulated that the choice of parameterization was left to the user, and so an IAU compliant precession implementation can be constructed using various combinations of the angles returned by the present routine.
5. The parameterization used by SOFA is the version of the Fukushima-Williams angles that refers directly to the GCRS pole. These angles may be calculated by calling the routine `iau_PFW06`. SOFA also supports the direct computation of the CIP GCRS  $X, Y$  by series, available by calling `iau_XY06`.
6. The agreement between the different parameterizations is at the  $1 \mu\text{s}$  level in the present era.
7. When constructing a precession formulation that refers to the GCRS pole rather than the dynamical pole, it may (depending on the choice of angles) be necessary to introduce the frame bias explicitly.

## REFERENCES :

1. Capitaine, N. & Wallace, P.T. & Chapront, J., 2003, *Astron.Astrophys.*, **412**, 567.
2. Hilton, J. *et al.*, 2006, *Celest.Mech.Dyn.Astron.*, **94**, 351.

---

**iau\_PB06***precession Euler angles, IAU 2006***iau\_PB06**

---

**CALL :**

CALL iau\_PB06 ( DATE1, DATE2, BZETA, BZ, BTHETA )

**ACTION :**

This routine forms three Euler angles which implement general precession from epoch J2000.0, using the IAU 2006 model. Frame bias (the offset between ICRS and mean J2000.0) is included.

**GIVEN :**

<i>DATE1</i>	d	TT as a two-part...
<i>DATE2</i>	d	... Julian Date (Note 1)

**RETURNED :**

<i>BZETA</i>	d	1st rotation $\zeta$ : radians clockwise around $z$
<i>BZ</i>	d	3rd rotation $z$ : radians clockwise around $z$
<i>BTHETA</i>	d	2nd rotation $\theta$ : radians counterclockwise around $y$

**NOTES :**

1. The TT date DATE1+DATE2 is a Julian Date, apportioned in any convenient way between the arguments DATE1 and DATE2. For example, JD(TT) = 2450123.7 could be expressed in any of these ways, among others:

DATE1	DATE2	
2450123.7D0	0D0	(JD method)
2451545.0D0	-1421.3D0	(J2000 method)
2400000.5D0	50123.2D0	(MJD method)
2450123.5D0	0.2D0	(date & time method)

The JD method is the most natural and convenient to use in cases where the loss of several decimal digits of resolution is acceptable. The J2000 method is best matched to the way the argument is handled internally and will deliver the optimum resolution. The MJD method and the date & time methods are both good compromises between resolution and convenience.

2. The traditional accumulated precession angles  $\zeta_A$ ,  $z_A$  and  $\theta_A$  cannot be obtained in the usual way, namely through polynomial expressions, because of the frame bias. The latter means that two of the angles undergo rapid changes near this date. They are instead the results of decomposing the precession-bias matrix obtained by using the Fukushima-Williams method, which does not suffer from the problem. The decomposition returns values which can be used in the conventional formulation and which include frame bias.
3. The three angles are returned in the conventional order, which is not the same as the order of the corresponding Euler rotations. The precession-bias matrix (GCRS to CIRS) is  $\mathbf{R}_3(-z) \mathbf{R}_2(+\theta) \mathbf{R}_3(-\zeta)$ .
4. Should  $\zeta_A$ ,  $z_A$ ,  $\theta_A$  angles be required that do **not** contain frame bias, they are available by calling the SOFA routine iau\_P06E.

---

**iau\_PFW06**                      *F-W precession angles, IAU 2006*                      **iau\_PFW06**

---

**CALL :**

CALL iau\_PFW06 ( DATE1, DATE2, GAMB, PHIB, PSIB, EPSA )

**ACTION :**

Precession angles, IAU 2006, Fukushima-Williams 4-angle formulation.

**GIVEN :**

*DATE1*     d                      TT as a two-part...  
*DATE2*     d                      ... Julian Date (Note 1)

**RETURNED :**

*GAMB*     d                      F-W angle  $\bar{\gamma}$  (radians)  
*PHIB*     d                      F-W angle  $\bar{\phi}$  (radians)  
*PSIB*     d                      F-W angle  $\bar{\psi}$  (radians)  
*EPSA*     d                      F-W angle  $\epsilon_A$  (radians)

**NOTES :**

1. The TT date DATE1+DATE2 is a Julian Date, apportioned in any convenient way between the arguments DATE1 and DATE2. For example, JD(TT) = 2450123.7 could be expressed in any of these ways, among others:

DATE1	DATE2	
2450123.7D0	0D0	(JD method)
2451545.0D0	-1421.3D0	(J2000 method)
2400000.5D0	50123.2D0	(MJD method)
2450123.5D0	0.2D0	(date & time method)

The JD method is the most natural and convenient to use in cases where the loss of several decimal digits of resolution is acceptable. The J2000 method is best matched to the way the argument is handled internally and will deliver the optimum resolution. The MJD method and the date & time methods are both good compromises between resolution and convenience.

2. Naming the following points:

e = J2000.0 ecliptic pole,  
p = GCRS pole,  
E = ecliptic pole of date and  
P = mean pole of date,

the four Fukushima-Williams angles are as follows:

$\bar{\gamma}$  = epE  
 $\bar{\phi}$  = pE  
 $\bar{\psi}$  = pEP  
 $\epsilon_A$  = EP



3. The matrix representing the combined effects of frame bias and precession is:

$$\mathbf{PB} = \mathbf{R}_1(-\epsilon_A) \mathbf{R}_3(-\bar{\psi}) \mathbf{R}_1(\bar{\phi}) \mathbf{R}_3(\bar{\gamma})$$

4. The matrix representing the combined effects of frame bias, precession and nutation is:

$$\mathbf{NPB} = \mathbf{R}_1(-(\epsilon_A + \delta\epsilon)) \mathbf{R}_3(-(\bar{\psi} + \delta\psi)) \mathbf{R}_1(\bar{\phi}) \mathbf{R}_3(\bar{\gamma})$$

where  $\delta\psi$  and  $\delta\epsilon$  are the nutation components with respect to the ecliptic of date.

**REFERENCE :**

Hilton, J. *et al.*, 2006, *Celest.Mech.Dyn.Astron.*, **94**, 351.

---

**iau\_PMAT00**                      *precession matrix, IAU 2000*                      **iau\_PMAT00**

**CALL :**

CALL iau\_PMAT00 ( DATE1, DATE2, RBP )

**ACTION :**

Precession matrix (including frame bias) from GCRS to a specified date, IAU 2000 model.

**GIVEN :**

*DATE1*      d                      TT as a two-part...  
*DATE2*      d                      ... Julian Date (Note 1)

**RETURNED :**

*RBP*              d(3,3)                      bias-precession matrix **BP** (Note 2)

**NOTES :**

1. The TT date DATE1+DATE2 is a Julian Date, apportioned in any convenient way between the arguments DATE1 and DATE2. For example, JD(TT) = 2450123.7 could be expressed in any of these ways, among others:

DATE1	DATE2	
2450123.7D0	0D0	(JD method)
2451545.0D0	-1421.3D0	(J2000 method)
2400000.5D0	50123.2D0	(MJD method)
2450123.5D0	0.2D0	(date & time method)

The JD method is the most natural and convenient to use in cases where the loss of several decimal digits of resolution is acceptable. The J2000 method is best matched to the way the argument is handled internally and will deliver the optimum resolution. The MJD method and the date & time methods are both good compromises between resolution and convenience.

2. The matrix operates in the sense

$$\mathbf{v}_{\text{date}} = \mathbf{BP} \mathbf{v}_{\text{GCRS}},$$

where the p-vector  $\mathbf{v}_{\text{date}}$  is with respect to the mean equatorial triad of the given date and the p-vector  $\mathbf{v}_{\text{GCRS}}$  is with respect to the Geocentric Celestial Reference System (IAU, 2000).

**REFERENCE :**

IAU: Trans. International Astronomical Union, Vol. XXIVB; Proc. 24th General Assembly, Manchester, UK. Resolutions B1.3, B1.6. (2000).

**iau\_PMAT06***precession matrix, IAU 2006***iau\_PMAT06****CALL :**

CALL iau\_PMAT06 ( DATE1, DATE2, RBP )

**ACTION :**

Precession matrix (including frame bias) from GCRS to a specified date, IAU 2006 model.

**GIVEN :**

<i>DATE1</i>	d	TT as a two-part...
<i>DATE2</i>	d	... Julian Date (Note 1)

**RETURNED :**

<i>RBP</i>	d(3,3)	bias-precession matrix <b>BP</b> (Note 2)
------------	--------	---

**NOTES :**

- The TT date DATE1+DATE2 is a Julian Date, apportioned in any convenient way between the arguments DATE1 and DATE2. For example, JD(TT) = 2450123.7 could be expressed in any of these ways, among others:

DATE1	DATE2	
2450123.7D0	0D0	(JD method)
2451545.0D0	-1421.3D0	(J2000 method)
2400000.5D0	50123.2D0	(MJD method)
2450123.5D0	0.2D0	(date & time method)

The JD method is the most natural and convenient to use in cases where the loss of several decimal digits of resolution is acceptable. The J2000 method is best matched to the way the argument is handled internally and will deliver the optimum resolution. The MJD method and the date & time methods are both good compromises between resolution and convenience.

- The matrix operates in the sense

$$\mathbf{v}_{\text{date}} = \mathbf{BP} \mathbf{v}_{\text{GCRS}},$$

where the p-vector  $\mathbf{v}_{\text{date}}$  is with respect to the mean equatorial triad of the given date and the p-vector  $\mathbf{v}_{\text{GCRS}}$  is with respect to the Geocentric Celestial Reference System (IAU, 2000).

**REFERENCES :**

- Capitaine, N. & Wallace, P.T., 2006, *Astron.Astrophys.*, **450**, 855-872.
- IAU: Trans. International Astronomical Union, Vol. XXIVB; Proc. 24th General Assembly, Manchester, UK. Resolutions B1.3, B1.6. (2000).
- Wallace, P.T. & Capitaine, N., 2006, *Astron.Astrophys.*, **459**, 981-985.

---

**iau\_PMAT76**                      *precession matrix, IAU 1976*                      **iau\_PMAT76**
**CALL :**

CALL iau\_PMAT76 ( DATE1, DATE2, RMATP )

**ACTION :**

Precession matrix from J2000.0 to a specified date, IAU 1976 model.

**GIVEN :**

*DATE1*     d                      TT as a two-part...  
*DATE2*     d                      ... Julian Date (Note 1)

**RETURNED :**

*RMATP*     d(3,3)                precession matrix **P** (Note 2)

**NOTES :**

1. The TT date DATE1+DATE2 is a Julian Date, apportioned in any convenient way between the arguments DATE1 and DATE2. For example, JD(TT) = 2450123.7 could be expressed in any of these ways, among others:

DATE1	DATE2	
2450123.7D0	0D0	(JD method)
2451545.0D0	-1421.3D0	(J2000 method)
2400000.5D0	50123.2D0	(MJD method)
2450123.5D0	0.2D0	(date & time method)

The JD method is the most natural and convenient to use in cases where the loss of several decimal digits of resolution is acceptable. The J2000 method is best matched to the way the argument is handled internally and will deliver the optimum resolution. The MJD method and the date & time methods are both good compromises between resolution and convenience.

2. The matrix operates in the sense

$$\mathbf{v}_{\text{date}} = \mathbf{P} \mathbf{v}_{\text{J2000}} ,$$

where the p-vector  $\mathbf{v}_{\text{date}}$  is with respect to the mean equatorial triad of the given date and the p-vector  $\mathbf{v}_{\text{J2000}}$  is with respect to the mean equatorial triad of the given date.

3. Though the matrix method itself is rigorous, the precession angles are expressed through canonical polynomials which are valid only for a limited time span. In addition, the IAU 1976 precession rate is known to be imperfect. The absolute accuracy of the present formulation is better than 0".1 from 1960 CE to 2040 CE, better than 1" from 1640 CE to 2360 CE, and remains below 3" for the whole of the period 500 CE to 3000 CE. The errors exceed 10" outside the range 1200 CE to 3900 CE, exceed 100" outside 4200 CE to 5600 CE and exceed 1000" outside 6800 CE to 8200 CE.

**REFERENCES :**

1. Kaplan, G.H., 1981, USNO circular No. 163, pA2.
2. Lieske, J.H., 1979, Astron.Astrophys. **73**, 282, equations (6) & (7), p283.

---

**iau\_PN00**                      *precession-nutation matrices, IAU 2000*                      **iau\_PN00**

**CALL :**

CALL iau\_PN00 ( DATE1, DATE2, DPSI, DEPS, EPSA, RB, RP, RBP, RN, RBPN )

**ACTION :**

Precession-nutation, IAU 2000 model: a multi-purpose routine, supporting classical (equinox-based) use directly and CIO-based use indirectly.

**GIVEN :**

<i>DATE1</i>	d	TT as a two-part...
<i>DATE2</i>	d	... Julian Date (Note 1)
<i>DPSI</i>	d	nutaton in longitude $\Delta\psi$ (radians, Note 2)
<i>DEPS</i>	d	nutaton in obliquity $\Delta\epsilon$ (radians, Note 2)

**RETURNED :**

<i>EPSA</i>	d	mean obliquity $\epsilon_A$ (Note 3)
<i>RB</i>	d(3,3)	frame bias matrix <b>B</b> (Note 4)
<i>RP</i>	d(3,3)	precession matrix <b>P</b> (Note 5)
<i>RBP</i>	d(3,3)	bias-precession matrix <b>BP</b> (Note 6)
<i>RN</i>	d(3,3)	nutaton matrix <b>N</b> (Note 7)
<i>RBPN</i>	d(3,3)	GCRS-to-true matrix <b>BPN</b> (Notes 8,9)

**NOTES :**

1. The TT date DATE1+DATE2 is a Julian Date, apportioned in any convenient way between the arguments DATE1 and DATE2. For example, JD(TT) = 2450123.7 could be expressed in any of these ways, among others:

DATE1	DATE2	
2450123.7D0	0D0	(JD method)
2451545.0D0	-1421.3D0	(J2000 method)
2400000.5D0	50123.2D0	(MJD method)
2450123.5D0	0.2D0	(date & time method)

The JD method is the most natural and convenient to use in cases where the loss of several decimal digits of resolution is acceptable. The J2000 method is best matched to the way the argument is handled internally and will deliver the optimum resolution. The MJD method and the date & time methods are both good compromises between resolution and convenience.

2. The caller is responsible for providing the nutation components; they are in longitude and obliquity, in radians and are with respect to the equinox and ecliptic of date. For high-accuracy applications, free core nutation should be included as well as any other relevant corrections to the position of the CIP.

3. The returned mean obliquity  $\epsilon_A$  is consistent with the IAU 2000 precession-nutation models.
4. The matrix **B** transforms vectors from GCRS to J2000.0 mean equator and equinox by applying frame bias.
5. The matrix **P** transforms vectors from J2000.0 mean equator and equinox to mean equator and equinox of date by applying precession.
6. The matrix **BP** transforms vectors from GCRS to mean equator and equinox of date by applying frame bias then precession. It is the product **P B**.
7. The matrix **N** transforms vectors from mean equator and equinox of date to true equator and equinox of date by applying the nutation (luni-solar + planetary).
8. The matrix **BPN** transforms vectors from GCRS to true equator and equinox of date. It is the product **N P B**, applying frame bias, precession and nutation in that order.

**REFERENCE :**

Capitaine, N., Chapront, J., Lambert, S. and Wallace, P., 2003, *Astron.Astrophys.* **400**, 1145-1154.

---

**iau\_PN00A**      *precession-nutation matrices, IAU 2000A*      **iau\_PN00A**

---

**CALL :**

CALL iau\_PN00A ( DATE1, DATE2, DPSI, DEPS, EPSA, RB, RP, RBP, RN, RBPN )

**ACTION :**

Precession-nutation, IAU 2000A model: a multi-purpose routine, supporting classical (equinox-based) use directly and CIO-based use indirectly.

**GIVEN :**

*DATE1*      d                      TT as a two-part...  
*DATE2*      d                      ... Julian Date (Note 1)

**RETURNED :**

*DPSI*      d                      nutation in longitude  $\Delta\psi$  (radians, Note 2)  
*DEPS*      d                      nutation in obliquity  $\Delta\epsilon$  (radians, Note 2)  
*EPSA*      d                      mean obliquity  $\epsilon_A$  (Note 3)  
*RB*        d(3,3)                    frame bias matrix **B** (Note 4)  
*RP*        d(3,3)                    precession matrix **P** (Note 5)  
*RBP*      d(3,3)                    bias-precession matrix **BP** (Note 6)  
*RN*        d(3,3)                    nutation matrix **N** (Note 7)  
*RBPN*     d(3,3)                    GCRS-to-true matrix **BPN** (Notes 8,9)

**NOTES :**

1. The TT date DATE1+DATE2 is a Julian Date, apportioned in any convenient way between the arguments DATE1 and DATE2. For example, JD(TT) = 2450123.7 could be expressed in any of these ways, among others:

DATE1	DATE2	
2450123.7D0	0D0	(JD method)
2451545.0D0	-1421.3D0	(J2000 method)
2400000.5D0	50123.2D0	(MJD method)
2450123.5D0	0.2D0	(date & time method)

The JD method is the most natural and convenient to use in cases where the loss of several decimal digits of resolution is acceptable. The J2000 method is best matched to the way the argument is handled internally and will deliver the optimum resolution. The MJD method and the date & time methods are both good compromises between resolution and convenience.

2. The returned nutation components  $\Delta\psi$ ,  $\Delta\epsilon$  (luni-solar + planetary, IAU 2000A) are in radians and with respect to the equinox and ecliptic of date. Free core nutation is omitted; for the utmost accuracy, use the iau\_PN00 routine, where the nutation components are caller-specified. For faster but slightly less accurate results, use the iau\_PN00B routine.

3. The returned mean obliquity  $\epsilon_A$  is consistent with the IAU 2000 precession.
4. The matrix  $\mathbf{B}$  transforms vectors from GCRS to J2000.0 mean equator and equinox by applying frame bias.
5. The matrix  $\mathbf{P}$  transforms vectors from J2000.0 mean equator and equinox to mean equator and equinox of date by applying precession.
6. The matrix  $\mathbf{BP}$  transforms vectors from GCRS to mean equator and equinox of date by applying frame bias then precession. It is the product  $\mathbf{PB}$ .
7. The matrix  $\mathbf{N}$  transforms vectors from mean equator and equinox of date to true equator and equinox of date by applying the nutation (luni-solar + planetary).
8. The matrix  $\mathbf{BPN}$  transforms vectors from GCRS to true equator and equinox of date. It is the product  $\mathbf{NPB}$ , applying frame bias, precession and nutation in that order.
9. The  $X, Y, Z$  coordinates of the IAU 2000A Celestial Intermediate Pole are elements (3,1-3) of the GCRS-to-true matrix  $\mathbf{BPN}$ .

**REFERENCE :**

Capitaine, N., Chapront, J., Lambert, S. and Wallace, P., 2003, *Astron.Astrophys.* **400**, 1145-1154.



---

**iau\_PN00B**      *precession-nutation matrices, IAU 2000B*      **iau\_PN00B**

---

**CALL :**

CALL iau\_PN00B ( DATE1, DATE2, DPSI, DEPS, EPSA, RB, RP, RBP, RN, RBPN )

**ACTION :**

Precession-nutation, IAU 2000B model: a multi-purpose routine, supporting classical (equinox-based) use directly and CIO-based use indirectly.

**GIVEN :**

<i>DATE1</i>	d	TT as a two-part...
<i>DATE2</i>	d	... Julian Date (Note 1)

**RETURNED :**

<i>DPSI</i>	d	nutaton in longitude $\Delta\psi$ (radians, Note 2)
<i>DEPS</i>	d	nutaton in obliquity $\Delta\epsilon$ (radians, Note 2)
<i>EPSA</i>	d	mean obliquity $\epsilon_A$ (Note 3)
<i>RB</i>	d(3,3)	frame bias matrix <b>B</b> (Note 4)
<i>RP</i>	d(3,3)	precession matrix <b>P</b> (Note 5)
<i>RBP</i>	d(3,3)	bias-precession matrix <b>BP</b> (Note 6)
<i>RN</i>	d(3,3)	nutaton matrix <b>N</b> (Note 7)
<i>RBPN</i>	d(3,3)	GCRS-to-true matrix <b>BPN</b> (Notes 8,9)

**NOTES :**

1. The TT date DATE1+DATE2 is a Julian Date, apportioned in any convenient way between the arguments DATE1 and DATE2. For example, JD(TT) = 2450123.7 could be expressed in any of these ways, among others:

DATE1	DATE2	
2450123.7D0	0D0	(JD method)
2451545.0D0	-1421.3D0	(J2000 method)
2400000.5D0	50123.2D0	(MJD method)
2450123.5D0	0.2D0	(date & time method)

The JD method is the most natural and convenient to use in cases where the loss of several decimal digits of resolution is acceptable. The J2000 method is best matched to the way the argument is handled internally and will deliver the optimum resolution. The MJD method and the date & time methods are both good compromises between resolution and convenience.

2. The returned nutation components  $\Delta\psi$ ,  $\Delta\epsilon$  (luni-solar + planetary, IAU 2000B) are in radians and with respect to the equinox and ecliptic of date. For more accurate results, but at the cost of increased computation, use the iau\_PN00A routine. For the utmost accuracy, use the iau\_PN00 routine, where the nutation components are caller-specified.

3. The returned mean obliquity  $\epsilon_A$  is consistent with the IAU 2000 precession.
4. The matrix **B** transforms vectors from GCRS to J2000.0 mean equator and equinox by applying frame bias.
5. The matrix **P** transforms vectors from J2000.0 mean equator and equinox to mean equator and equinox of date by applying precession.
6. The matrix **BP** transforms vectors from GCRS to mean equator and equinox of date by applying frame bias then precession. It is the product **P B**.
7. The matrix **N** transforms vectors from mean equator and equinox of date to true equator and equinox of date by applying the nutation (luni-solar + planetary).
8. The matrix **BPN** transforms vectors from GCRS to true equator and equinox of date. It is the product **N P B**, applying frame bias, precession and nutation in that order.
9. The  $X, Y, Z$  coordinates of the IAU 2000B Celestial Intermediate Pole are elements (3,1-3) of the GCRS-to-true matrix **BPN**.

**REFERENCE :**

Capitaine, N., Chapront, J., Lambert, S. and Wallace, P., 2003, *Astron.Astrophys.* **400**, 1145-1154.

**iau\_PN06***precession-nutation matrices, IAU 2006***iau\_PN06****CALL :**

CALL iau\_PN06 ( DATE1, DATE2, DPSI, DEPS, EPSA, RB, RP, RBP, RN, RBPN )

**ACTION :**

Precession-nutation, IAU 2006 model: a multi-purpose routine, supporting classical (equinox-based) use directly and CIO-based use indirectly.

**GIVEN :**

<i>DATE1</i>	d	TT as a two-part...
<i>DATE2</i>	d	... Julian Date (Note 1)
<i>DPSI</i>	d	nutaton in longitude $\Delta\psi$ (radians, Note 2)
<i>DEPS</i>	d	nutaton in obliquity $\Delta\epsilon$ (radians, Note 2)

**RETURNED :**

<i>EPSA</i>	d	mean obliquity $\epsilon_A$ (Note 3)
<i>RB</i>	d(3,3)	frame bias matrix <b>B</b> (Note 4)
<i>RP</i>	d(3,3)	precession matrix <b>P</b> (Note 5)
<i>RBP</i>	d(3,3)	bias-precession matrix <b>BP</b> (Note 6)
<i>RN</i>	d(3,3)	nutaton matrix <b>N</b> (Note 7)
<i>RBPN</i>	d(3,3)	GCRS-to-true matrix <b>BP</b> N (Notes 8,9)

**NOTES :**

1. The TT date DATE1+DATE2 is a Julian Date, apportioned in any convenient way between the arguments DATE1 and DATE2. For example, JD(TT) = 2450123.7 could be expressed in any of these ways, among others:

DATE1	DATE2	
2450123.7D0	0D0	(JD method)
2451545.0D0	-1421.3D0	(J2000 method)
2400000.5D0	50123.2D0	(MJD method)
2450123.5D0	0.2D0	(date & time method)

- The JD method is the most natural and convenient to use in cases where the loss of several decimal digits of resolution is acceptable. The J2000 method is best matched to the way the argument is handled internally and will deliver the optimum resolution. The MJD method and the date & time methods are both good compromises between resolution and convenience.
2. The caller is responsible for providing the nutation components; they are in longitude and obliquity, in radians and are with respect to the equinox and ecliptic of date. For high-accuracy applications, free core nutation should be included as well as any other relevant corrections to the position of the CIP.
  3. The returned mean obliquity  $\epsilon_A$  is consistent with the IAU 2006 precession.

4. The matrix **B** transforms vectors from GCRS to J2000.0 mean equator and equinox by applying frame bias.
5. The matrix **P** transforms vectors from J2000.0 mean equator and equinox to mean equator and equinox of date by applying precession.
6. The matrix **BP** transforms vectors from GCRS to mean equator and equinox of date by applying frame bias then precession. It is the product **P B**.
7. The matrix **N** transforms vectors from mean equator and equinox of date to true equator and equinox of date by applying the nutation (luni-solar + planetary).
8. The matrix **BPN** transforms vectors from GCRS to true equator and equinox of date. It is the product **N P B**, applying frame bias, precession and nutation in that order.
9. The  $X, Y, Z$  coordinates of the IAU 2006 Celestial Intermediate Pole are elements (3,1-3) of the GCRS-to-true matrix **BPN**.

**REFERENCE :**

Capitaine, N., Chapront, J., Lambert, S. and Wallace, P., 2003, *Astron.Astrophys.* **400**, 1145-1154.

---

**iau\_PN06A**      *precession-nutation matrices, IAU 2006A*      **iau\_PN06A**

---

**CALL :**

CALL iau\_PN06A ( DATE1, DATE2, DPSI, DEPS, EPSA, RB, RP, RBP, RN, RBPN )

**ACTION :**

Precession-nutation, IAU 2006A model: a multi-purpose routine, supporting classical (equinox-based) use directly and CIO-based use indirectly.

**GIVEN :**

<i>DATE1</i>	d	TT as a two-part...
<i>DATE2</i>	d	... Julian Date (Note 1)

**RETURNED :**

<i>DPSI</i>	d	nutaton in longitude $\Delta\psi$ (radians, Note 2)
<i>DEPS</i>	d	nutaton in obliquity $\Delta\epsilon$ (radians, Note 2)
<i>EPSA</i>	d	mean obliquity $\epsilon_A$ (Note 3)
<i>RB</i>	d(3,3)	frame bias matrix <b>B</b> (Note 4)
<i>RP</i>	d(3,3)	precession matrix <b>P</b> (Note 5)
<i>RBP</i>	d(3,3)	bias-precession matrix <b>BP</b> (Note 6)
<i>RN</i>	d(3,3)	nutaton matrix <b>N</b> (Note 7)
<i>RBPN</i>	d(3,3)	GCRS-to-true matrix <b>BPBPN</b> (Notes 8,9)

**NOTES :**

1. The TT date DATE1+DATE2 is a Julian Date, apportioned in any convenient way between the arguments DATE1 and DATE2. For example, JD(TT) = 2450123.7 could be expressed in any of these ways, among others:

DATE1	DATE2	
2450123.7D0	0D0	(JD method)
2451545.0D0	-1421.3D0	(J2000 method)
2400000.5D0	50123.2D0	(MJD method)
2450123.5D0	0.2D0	(date & time method)

The JD method is the most natural and convenient to use in cases where the loss of several decimal digits of resolution is acceptable. The J2000 method is best matched to the way the argument is handled internally and will deliver the optimum resolution. The MJD method and the date & time methods are both good compromises between resolution and convenience.

2. The returned nutation components  $\Delta\psi$ ,  $\Delta\epsilon$  (luni-solar + planetary, IAU 2006A) are in radians and with respect to the equinox and ecliptic of date. Free core nutation is omitted; for the utmost accuracy, use the iau\_PN06 routine, where the nutation components are caller-specified.
3. The returned mean obliquity  $\epsilon_A$  is consistent with the IAU 2000 precession.

4. The matrix **B** transforms vectors from GCRS to J2000.0 mean equator and equinox by applying frame bias.
5. The matrix **P** transforms vectors from J2000.0 mean equator and equinox to mean equator and equinox of date by applying precession.
6. The matrix **BP** transforms vectors from GCRS to mean equator and equinox of date by applying frame bias then precession. It is the product **P B**.
7. The matrix **N** transforms vectors from mean equator and equinox of date to true equator and equinox of date by applying the nutation (luni-solar + planetary).
8. The matrix **BPN** transforms vectors from GCRS to true equator and equinox of date. It is the product **N P B**, applying frame bias, precession and nutation in that order.
9. The  $X, Y, Z$  coordinates of the IAU 2006A Celestial Intermediate Pole are elements (3,1-3) of the GCRS-to-true matrix **BPN**.

**REFERENCE :**

Capitaine, N. & Wallace, P.T., 2006, *Astron.Astrophys.* **450**, 855.

---

**iau\_PNM00A**      *precession-nutation matrix, IAU 2000A*      **iau\_PNM00A**
**CALL :**

CALL iau\_PNM00A ( DATE1, DATE2, RBPN )

**ACTION :**

Form the matrix of precession-nutation for a given date (including frame bias), equinox based, IAU 2000A model.

**GIVEN :**

*DATE1*      d                      TT as a two-part...  
*DATE2*      d                      ... Julian Date (Note 1)

**RETURNED :**

*RBPN*      d(3,3)                      classical bias-precession-nutation matrix **BPN** (Note 2)

**NOTES :**

1. The TT date *DATE1*+*DATE2* is a Julian Date, apportioned in any convenient way between the arguments *DATE1* and *DATE2*. For example,  $JD(TT) = 2450123.7$  could be expressed in any of these ways, among others:

<i>DATE1</i>	<i>DATE2</i>	
2450123.7D0	0D0	(JD method)
2451545.0D0	-1421.3D0	(J2000 method)
2400000.5D0	50123.2D0	(MJD method)
2450123.5D0	0.2D0	(date & time method)

The JD method is the most natural and convenient to use in cases where the loss of several decimal digits of resolution is acceptable. The J2000 method is best matched to the way the argument is handled internally and will deliver the optimum resolution. The MJD method and the date & time methods are both good compromises between resolution and convenience.

2. The matrix operates in the sense

$$\mathbf{v}_{\text{date}} = \mathbf{BPN} \mathbf{v}_{\text{GCRS}},$$

where the p-vector  $\mathbf{v}_{\text{date}}$  is with respect to the true equatorial triad of date *DATE1*+*DATE2* and the p-vector  $\mathbf{v}_{\text{GCRS}}$  is with respect to the Geocentric Celestial Reference System (IAU, 2000).

3. A faster, but slightly less accurate, result (about 1 mas) can be obtained by using instead the *iau\_PNM00B* routine.

**REFERENCE :**

IAU: Trans. International Astronomical Union, Vol. XXIVB; Proc. 24th General Assembly, Manchester, UK. Resolutions B1.3, B1.6. (2000).

---

**iau\_PNM00B**      *precession-nutation matrix, IAU 2000B*      **iau\_PNM00B**

**CALL :**

CALL iau\_PNM00B ( DATE1, DATE2, RBPN )

**ACTION :**

Form the matrix of precession-nutation for a given date (including frame bias), equinox based, IAU 2000B model.

**GIVEN :**

*DATE1*      d                    TT as a two-part...  
*DATE2*      d                    ... Julian Date (Note 1)

**RETURNED :**

*RBPN*      d(3,3)                classical bias-precession-nutation matrix **BPN** (Note 2)

**NOTES :**

1. The TT date *DATE1*+*DATE2* is a Julian Date, apportioned in any convenient way between the arguments *DATE1* and *DATE2*. For example,  $JD(TT) = 2450123.7$  could be expressed in any of these ways, among others:

<i>DATE1</i>	<i>DATE2</i>	
2450123.7D0	0D0	(JD method)
2451545.0D0	-1421.3D0	(J2000 method)
2400000.5D0	50123.2D0	(MJD method)
2450123.5D0	0.2D0	(date & time method)

The JD method is the most natural and convenient to use in cases where the loss of several decimal digits of resolution is acceptable. The J2000 method is best matched to the way the argument is handled internally and will deliver the optimum resolution. The MJD method and the date & time methods are both good compromises between resolution and convenience.

2. The matrix operates in the sense

$$\mathbf{v}_{\text{date}} = \mathbf{BPN} \mathbf{v}_{\text{GCRS}},$$

where the p-vector  $\mathbf{v}_{\text{date}}$  is with respect to the true equatorial triad of date *DATE1*+*DATE2* and the p-vector  $\mathbf{v}_{\text{GCRS}}$  is with respect to the Geocentric Celestial Reference System (IAU, 2000).

3. The present routine is faster, but slightly less accurate (about 1 mas), than the *iau\_PNM00A* routine.

**REFERENCE :**

IAU: Trans. International Astronomical Union, Vol. XXIVB; Proc. 24th General Assembly, Manchester, UK. Resolutions B1.3, B1.6. (2000).



---

**iau\_PNM06A**      *precession-nutation matrix, IAU 2006A*      **iau\_PNM06A**
**CALL :**

CALL iau\_PNM06A ( DATE1, DATE2, RBPN )

**ACTION :**

Form the matrix of precession-nutation for a given date (including frame bias), equinox-based, IAU 2006 precession and IAU 2000A nutation models.

**GIVEN :**

*DATE1*      d                      TT as a two-part...  
*DATE2*      d                      ... Julian Date (Note 1)

**RETURNED :**

*RBPN*      d(3,3)                      classical bias-precession-nutation matrix **BPN** (Note 2)

**NOTES :**

1. The TT date *DATE1+DATE2* is a Julian Date, apportioned in any convenient way between the arguments *DATE1* and *DATE2*. For example,  $JD(TT) = 2450123.7$  could be expressed in any of these ways, among others:

<i>DATE1</i>	<i>DATE2</i>	
2450123.7D0	0D0	(JD method)
2451545.0D0	-1421.3D0	(J2000 method)
2400000.5D0	50123.2D0	(MJD method)
2450123.5D0	0.2D0	(date & time method)

The JD method is the most natural and convenient to use in cases where the loss of several decimal digits of resolution is acceptable. The J2000 method is best matched to the way the argument is handled internally and will deliver the optimum resolution. The MJD method and the date & time methods are both good compromises between resolution and convenience.

2. The matrix operates in the sense

$$\mathbf{v}_{\text{date}} = \mathbf{BPN} \mathbf{v}_{\text{GCRS}},$$

where the p-vector  $\mathbf{v}_{\text{date}}$  is with respect to the true equatorial triad of date *DATE1+DATE2* and the p-vector  $\mathbf{v}_{\text{GCRS}}$  is with respect to the Geocentric Celestial Reference System (IAU, 2000).

**REFERENCES :**

1. Capitaine, N. & Wallace, P.T., 2006, *Astron.Astrophys.*, **450**, 855-872.
2. IAU: Trans. International Astronomical Union, Vol. XXIVB; Proc. 24th General Assembly, Manchester, UK. Resolutions B1.3, B1.6. (2000).

---

**iau\_PNM80**      *precession-nutation matrix, IAU 1976/1980*      **iau\_PNM80**

**CALL :**

CALL iau\_PNM80 ( DATE1, DATE2, RBPN )

**ACTION :**

Form the matrix of precession-nutation for a given date, equinox based, IAU 1976 precession, IAU 1980 nutation models.

**GIVEN :**

*DATE1*      d                      TT as a two-part...  
*DATE2*      d                      ... Julian Date (Note 1)

**RETURNED :**

*RBPN*      d(3,3)                      classical precession-nutation matrix **PN** (Note 2)

**NOTES :**

1. The TT date DATE1+DATE2 is a Julian Date, apportioned in any convenient way between the arguments DATE1 and DATE2. For example, JD(TT) = 2450123.7 could be expressed in any of these ways, among others:

DATE1	DATE2	
2450123.7D0	0D0	(JD method)
2451545.0D0	-1421.3D0	(J2000 method)
2400000.5D0	50123.2D0	(MJD method)
2450123.5D0	0.2D0	(date & time method)

The JD method is the most natural and convenient to use in cases where the loss of several decimal digits of resolution is acceptable. The J2000 method is best matched to the way the argument is handled internally and will deliver the optimum resolution. The MJD method and the date & time methods are both good compromises between resolution and convenience.

2. The matrix operates in the sense

$$\mathbf{v}_{\text{date}} = \mathbf{PN} \mathbf{v}_{\text{J2000}} ,$$

where the p-vector  $\mathbf{v}_{\text{date}}$  is with respect to the true equatorial triad of date DATE1+DATE2 and the p-vector  $\mathbf{v}_{\text{J2000}}$  is with respect to the mean equatorial triad of epoch J2000.0.

**REFERENCE :**

Seidelmann, P.K. (Ed.) (1992), *Explanatory Supplement to the Astronomical Almanac*, University Science Books, Section 3.3 (p145).

**iau\_POM00***polar motion matrix, IAU 2000***iau\_POM00****CALL :**

CALL iau\_POM00 ( XP, YP, SP, RPOM )

**ACTION :**

Form the matrix of polar motion for a given date, IAU 2000.

**GIVEN :**

<i>XP, YP</i>	d	coordinates of the pole (radians, Note 1)
<i>SP</i>	d	the TIO locator $s'$ (radians, Note 2)

**RETURNED :**

<i>RPOM</i>	d(3,3)	polar-motion matrix $\mathbf{W}$ (Note 3)
-------------	--------	---

**NOTES :**

1. *XP* and *YP* are the coordinates (in radians) of the Celestial Intermediate Pole with respect to the International Terrestrial Reference System (see IERS Conventions 2003), measured along the meridians  $0^\circ$  and  $90^\circ$  west respectively.
2. *SP* is the TIO locator  $s'$ , in radians, which positions the Terrestrial Intermediate Origin on the equator. It is obtained from polar motion observations by numerical integration, and so is in principle unpredictable. However, it is dominated by a secular drift of about  $47\mu\text{as}$  per century, and so can be taken into account by using  $s' = -47t$ , where  $t$  is centuries since J2000.0. The routine `iau_SP00` implements this approximation.
3. The matrix operates in the sense

$$\mathbf{v}_{\text{TRS}} = \mathbf{W} \mathbf{v}_{\text{CIP}} ,$$

meaning that it is the final rotation when computing the pointing direction to a celestial source for a terrestrial observer.

**REFERENCE :**

McCarthy, D.D., Petit, G. (eds.), 2004, IERS Conventions (2003), IERS Technical Note No. 32, BKG.

---

**iau\_PR00**                      *precession-rate adjustments, IAU 2000*                      **iau\_PR00**

**CALL :**

CALL iau\_PR00 ( DATE1, DATE2, DPSIPR, DEPSPR )

**ACTION :**

Precession-rate part of the IAU 2000 precession-nutation models (part of MHB2000).

**GIVEN :**

*DATE1*     d                      TT as a two-part...  
*DATE2*     d                      ... Julian Date (Note 1)

**RETURNED :**

*DPSIPR*    d                      adjustment in longitude  $\Delta\psi$  (radians, Notes 2,3)  
*DEPSPR*    d                      adjustment in obliquity  $\Delta\epsilon$  (radians, Notes 2,3)

**NOTES :**

1. The TT date DATE1+DATE2 is a Julian Date, apportioned in any convenient way between the arguments DATE1 and DATE2. For example, JD(TT) = 2450123.7 could be expressed in any of these ways, among others:

DATE1	DATE2	
2450123.7D0	0D0	(JD method)
2451545.0D0	-1421.3D0	(J2000 method)
2400000.5D0	50123.2D0	(MJD method)
2450123.5D0	0.2D0	(date & time method)

The JD method is the most natural and convenient to use in cases where the loss of several decimal digits of resolution is acceptable. The J2000 method is best matched to the way the argument is handled internally and will deliver the optimum resolution. The MJD method and the date & time methods are both good compromises between resolution and convenience.

2. The precession adjustments are expressed as “nutation components”, corrections in longitude and obliquity with respect to the J2000.0 equinox and ecliptic.
3. Although the MHB2000 precession adjustments ( $\Delta\psi, \Delta\epsilon$ ) are stated to be with respect to Lieske *et al.* (1977), the MHB2000 model does not specify which set of Euler angles are to be used and how the adjustments are to be applied. The most literal and straightforward procedure is to adopt the four-rotation

$$\mathbf{P} = \mathbf{R}_3(\chi_A) \mathbf{R}_1(-\omega_A) \mathbf{R}_3(-\psi_A) \mathbf{R}_1(\epsilon_0)$$

option, and to add  $\Delta\psi$  to  $\psi_A$  and  $\Delta\epsilon$  to both  $\omega_A$  and  $\epsilon_A$ .

4. This is an implementation of one aspect of the IAU 2000A nutation model, formally adopted by the IAU General Assembly in 2000, namely MHB2000 (Mathews *et al.* 2002).

**REFERENCES :**

1. Lieske, J.H., Lederle, T., Fricke, W. & Morando, B., 1977, *Astron.Astrophys.*, **58**, 1-16.
2. Mathews, P.M., Herring, T.A., Buffet, B.A., 2002, *J.Geophys.Res.*, **107**, B4. The MHB2000 code itself was obtained on 2002 September 9 from <ftp://maia.usno.navy.mil/conv2000/chapter5/IAU2000A>.
3. Wallace, P.T., 2002, *Software for Implementing the IAU 2000 Resolutions*, in IERS Workshop 5.1.

---

**iau\_PREC76**      *precession 3-2-3 Euler angles, IAU 1976*      **iau\_PREC76**

---

**CALL :**

CALL iau\_PREC76 ( DATE01, DATE02, DATE11, DATE12, ZETA, Z, THETA )

**ACTION :**

IAU 1976 precession model.

**GIVEN :**

*DATE01*    d            start TT as a two-part...  
*DATE02*    d            ... Julian Date (Note 1)  
*DATE11*    d            end TT as a two-part...  
*DATE12*    d            ... Julian Date (Note 1)

**RETURNED :**

*ZETA*      d            1st rotation: radians clockwise around *z*  
*Z*          d            3rd rotation: radians clockwise around *z*  
*THETA*     d            2nd rotation: radians counterclockwise around *y*

**NOTES :**

1. The dates DATE01+DATE02 and DATE11+DATE12 are Julian Dates, apportioned in any convenient way between the arguments DATE<sub>n</sub>1 and DATE<sub>n</sub>2. For example, JD(TT)=2450123.7 could be expressed in any of these ways, among others:

DATE <sub>n</sub> 1	DATE <sub>n</sub> 2	
2450123.7D0	0D0	(JD method)
2451545.0D0	-1421.3D0	(J2000 method)
2400000.5D0	50123.2D0	(MJD method)
2450123.5D0	0.2D0	(date & time method)

The JD method is the most natural and convenient to use in cases where the loss of several decimal digits of resolution is acceptable. The J2000 method is best matched to the way the argument is handled internally and will deliver the optimum optimum resolution. The MJD method and the date & time methods are both good compromises between resolution and convenience. The two dates may be expressed using different methods, but at the risk of losing some resolution.

2. The accumulated precession angles  $\zeta$ ,  $z$  and  $\theta$  are expressed through canonical polynomials which are valid only for a limited time span. In addition, the IAU 1976 precession rate is known to be imperfect. The absolute accuracy of the present formulation is better than 0".1 from 1960 CE to 2040 CE, better than 1" from 1640 CE to 2360 CE, and remains below 3" for the whole of the period 500 CE to 3000 CE. The errors exceed 10" outside the range 1200 CE to 3900 CE, exceed 100" outside 4200 CE to 5600 CE and exceed 1000" outside 6800 CE to 8200 CE.
3. The three angles are returned in the conventional order, which is not the same as the order of the corresponding Euler rotations. The precession matrix is given by

$$\mathbf{P} = \mathbf{R}_3(-z) \mathbf{R}_2(+\theta) \mathbf{R}_3(-\zeta).$$

**REFERENCE :**

Lieske, J.H., 1979, *Astron.Astrophys.* **73**, 282, equations (6) & (7), p283.

**iau\_RX***rotate r-matrix about x axis***iau\_RX****CALL :**

CALL iau\_RX ( PHI, R )

**ACTION :**Rotate an r-matrix about the *x*-axis.**GIVEN :***PHI*      d              angle  $\phi$  (radians)**GIVEN and RETURNED :***R*              d(3,3)              r-matrix, rotated**NOTES :**

1. Calling this routine with positive  $\phi$  incorporates in the supplied r-matrix *R* an additional rotation, about the *x*-axis, anticlockwise as seen looking towards the origin from positive *x*.
2. The additional rotation can be represented by this matrix:

$$\begin{pmatrix} 1 & 0 & 0 \\ 0 & +\cos \phi & +\sin \phi \\ 0 & -\sin \phi & +\cos \phi \end{pmatrix}$$

---

**iau\_RXP**                      *product of r-matrix and p-vector*                      **iau\_RXP**

**CALL :**

CALL iau\_RXP ( R, P, RP )

**ACTION :**

Multiply a p-vector by an r-matrix.

**GIVEN :**

<i>R</i>	d(3,3)	r-matrix
<i>P</i>	d(3)	p-vector

**RETURNED :**

<i>RP</i>	d(3)	<i>R * P</i>
-----------	------	--------------



---

**iau\_RXR***r-matrix multiply***iau\_RXR****CALL :**

CALL iau\_RXR ( A, B, ATB )

**ACTION :**

Multiply two r-matrices.

**GIVEN :**

<i>A</i>	d(3,3)	first r-matrix
<i>B</i>	d(3,3)	second r-matrix

**RETURNED :**

<i>ATB</i>	d(3,3)	$A * B$
------------	--------	---------

---

<b>iau_RY</b>	<i>rotate r-matrix about y axis</i>	<b>iau_RY</b>
---------------	-------------------------------------	---------------

**CALL :**

```
CALL iau_RY ( THETA, R )
```

**ACTION :**

Rotate an r-matrix about the  $y$ -axis.

**GIVEN :**

*THETA*    d                    angle  $\theta$  (radians)

**GIVEN and RETURNED :**

*R*            d(3,3)            r-matrix, rotated

**NOTES :**

1. Calling this routine with positive  $\theta$  incorporates in the supplied r-matrix  $R$  an additional rotation, about the  $y$ -axis, anticlockwise as seen looking towards the origin from positive  $y$ .
2. The additional rotation can be represented by this matrix:

$$\begin{pmatrix} +\cos\theta & 0 & -\sin\theta \\ 0 & 1 & 0 \\ +\sin\theta & 0 & +\cos\theta \end{pmatrix}$$

**iau\_RZ***rotate r-matrix about z axis***iau\_RZ****CALL :**

CALL iau\_RZ ( PSI, R )

**ACTION :**Rotate an r-matrix about the *z*-axis.**GIVEN :***PSI*      d              angle  $\psi$  (radians)**GIVEN and RETURNED :***R*              d(3,3)              r-matrix, rotated**NOTES :**

1. Calling this routine with positive  $\psi$  incorporates in the supplied r-matrix *R* an additional rotation, about the *z*-axis, anticlockwise as seen looking towards the origin from positive *z*.
2. The additional rotation can be represented by this matrix:

$$\begin{pmatrix} +\cos\psi & +\sin\psi & 0 \\ -\sin\psi & +\cos\psi & 0 \\ 0 & 0 & 1 \end{pmatrix}$$

---

**iau\_S00**                      *CIO locator  $s$  given CIP  $X, Y$ , IAU 2000A*                      **iau\_S00**

**CALL :**

D = iau\_S00 ( DATE1, DATE2, X, Y )

**ACTION :**

The CIO locator  $s$ , positioning the Celestial Intermediate Origin on the equator of the Celestial Intermediate Pole, given the CIP's  $X, Y$  coordinates. Compatible with IAU 2000A precession-nutation.

**GIVEN :**

<i>DATE1</i>	d	TT as a two-part...
<i>DATE2</i>	d	... Julian Date (Note 1)
<i>X, Y</i>	d	CIP coordinates (Note 3)

**RETURNED** (function value) :

d	The CIO locator $s$ in radians (Note 2)
---	---

**NOTES :**

1. The TT date  $DATE1+DATE2$  is a Julian Date, apportioned in any convenient way between the arguments  $DATE1$  and  $DATE2$ . For example,  $JD(TT) = 2450123.7$  could be expressed in any of these ways, among others:

DATE1	DATE2	
2450123.7D0	0D0	(JD method)
2451545.0D0	-1421.3D0	(J2000 method)
2400000.5D0	50123.2D0	(MJD method)
2450123.5D0	0.2D0	(date & time method)

The JD method is the most natural and convenient to use in cases where the loss of several decimal digits of resolution is acceptable. The J2000 method is best matched to the way the argument is handled internally and will deliver the optimum resolution. The MJD method and the date & time methods are both good compromises between resolution and convenience.

2. The CIO locator  $s$  is the difference between the right ascensions of the same point in two systems: the two systems are the GCRS and the CIP,CIO, and the point is the ascending node of the CIP equator. The quantity  $s$  remains below  $0''.1$  throughout 1900-2100.
3. The series used to compute  $s$  is in fact for  $s + XY/2$ , where  $X$  and  $Y$  are the  $x$  and  $y$  components of the CIP unit vector; this series is more compact than a direct series for  $s$  would be. This routine requires  $X$  and  $Y$  to be supplied by the caller, who is responsible for providing values that are consistent with the supplied date.
4. The model is consistent with the IAU 2000A precession-nutation.

**REFERENCES :**

1. Capitaine, N., Chapront, J., Lambert, S. & Wallace, P., 2003, *Astron.Astrophys.* **400**, 1145-1154.
2. McCarthy, D.D., Petit, G. (eds.), 2004, *IERS Conventions (2003)*, IERS Technical Note No. 32, BKG.

---

**iau\_S00A** *CIO locator  $s$ , IAU 2000A* **iau\_S00A**

**CALL :**

D = iau\_S00A ( DATE1, DATE2, X, Y )

**ACTION :**

The CIO locator  $s$ , positioning the Celestial Intermediate Origin on the equator of the Celestial Intermediate Pole, using the IAU 2000A precession-nutation model.

**GIVEN :**

*DATE1*     d                    TT as a two-part...  
*DATE2*     d                    ... Julian Date (Note 1)

**RETURNED** (function value) :

d                    the CIO locator  $s$  in radians (Note 2)

**NOTES :**

1. The TT date DATE1+DATE2 is a Julian Date, apportioned in any convenient way between the arguments DATE1 and DATE2. For example, JD(TT) = 2450123.7 could be expressed in any of these ways, among others:

DATE1	DATE2	
2450123.7D0	0D0	(JD method)
2451545.0D0	-1421.3D0	(J2000 method)
2400000.5D0	50123.2D0	(MJD method)
2450123.5D0	0.2D0	(date & time method)

The JD method is the most natural and convenient to use in cases where the loss of several decimal digits of resolution is acceptable. The J2000 method is best matched to the way the argument is handled internally and will deliver the optimum resolution. The MJD method and the date & time methods are both good compromises between resolution and convenience.

2. The CIO locator  $s$  is the difference between the right ascensions of the same point in two systems: the two systems are the GCRS and the CIP,CIO, and the point is the ascending node of the CIP equator. The quantity  $s$  remains below 0".1 throughout 1900-2100.
3. The series used to compute  $s$  is in fact for  $s + XY/2$ , where  $X$  and  $Y$  are the  $x$  and  $y$  components of the CIP unit vector; this series is more compact than a direct series for  $s$  would be. The present routine uses the full IAU 2000A nutation model when predicting the CIP position. Faster results, with no significant loss of accuracy, can be obtained via the routine iau\_S00B, which uses instead the IAU 2000B truncated model.

**REFERENCES :**

1. Capitaine, N., Chapront, J., Lambert, S. & Wallace, P., 2003, *Astron.Astrophys.* **400**, 1145-1154.
2. McCarthy, D.D., Petit, G. (eds.), 2004, *IERS Conventions (2003)*, IERS Technical Note No. 32, BKG.

---

**iau\_S00B** *CIO locator  $s$ , IAU 2000B* **iau\_S00B**

---

**CALL :**

D = iau\_S00B ( DATE1, DATE2, X, Y )

**ACTION :**

The CIO locator  $s$ , positioning the Celestial Intermediate Origin on the equator of the Celestial Intermediate Pole, using the IAU 2000B precession-nutation model.

**GIVEN :**

*DATE1*     d            TT as a two-part...  
*DATE2*     d            ... Julian Date (Note 1)

**RETURNED** (function value) :

d                    the CIO locator  $s$  in radians (Note 2)

**NOTES :**

1. The TT date DATE1+DATE2 is a Julian Date, apportioned in any convenient way between the arguments DATE1 and DATE2. For example, JD(TT) = 2450123.7 could be expressed in any of these ways, among others:

DATE1	DATE2	
2450123.7D0	0D0	(JD method)
2451545.0D0	-1421.3D0	(J2000 method)
2400000.5D0	50123.2D0	(MJD method)
2450123.5D0	0.2D0	(date & time method)

The JD method is the most natural and convenient to use in cases where the loss of several decimal digits of resolution is acceptable. The J2000 method is best matched to the way the argument is handled internally and will deliver the optimum resolution. The MJD method and the date & time methods are both good compromises between resolution and convenience.

2. The CIO locator  $s$  is the difference between the right ascensions of the same point in two systems: the two systems are the GCRS and the CIP,CIO, and the point is the ascending node of the CIP equator. The quantity  $s$  remains below 0".1 throughout 1900-2100.
3. The series used to compute  $s$  is in fact for  $s + XY/2$ , where  $X$  and  $Y$  are the  $x$  and  $y$  components of the CIP unit vector; this series is more compact than a direct series for  $s$  would be. The present routine uses the IAU 2000B truncated nutation model when predicting the CIP position. The routine `iau_S00A` uses instead the full IAU 2000A model, but with no significant increase in accuracy and at some cost in speed.

**REFERENCES :**

1. Capitaine, N., Chapront, J., Lambert, S. & Wallace, P., 2003, *Astron.Astrophys.* **400**, 1145-1154.
2. McCarthy, D.D., Petit, G. (eds.), 2004, *IERS Conventions (2003)*, IERS Technical Note No. 32, BKG.

---

**iau\_S06**                    *CIO locator  $s$  given CIP  $X, Y$ , IAU 2006/2000A*                    **iau\_S06**

**CALL :**

D = iau\_S06 ( DATE1, DATE2, X, Y )

**ACTION :**

The CIO locator  $s$ , positioning the Celestial Intermediate Origin on the equator of the Celestial Intermediate Pole, given the CIP's  $X, Y$  coordinates. Compatible with IAU 2006/2000A precession-nutation.

**GIVEN :**

<i>DATE1</i>	d	TT as a two-part...
<i>DATE2</i>	d	... Julian Date (Note 1)
<i>X, Y</i>	d	CIP coordinates (Note 3)

**RETURNED** (function value) :

d                    The CIO locator  $s$  in radians (Note 2)

**NOTES :**

1. The TT date DATE1+DATE2 is a Julian Date, apportioned in any convenient way between the arguments DATE1 and DATE2. For example,  $JD(TT) = 2450123.7$  could be expressed in any of these ways, among others:

DATE1	DATE2	
2450123.7D0	0D0	(JD method)
2451545.0D0	-1421.3D0	(J2000 method)
2400000.5D0	50123.2D0	(MJD method)
2450123.5D0	0.2D0	(date & time method)

The JD method is the most natural and convenient to use in cases where the loss of several decimal digits of resolution is acceptable. The J2000 method is best matched to the way the argument is handled internally and will deliver the optimum resolution. The MJD method and the date & time methods are both good compromises between resolution and convenience.

2. The CIO locator  $s$  is the difference between the right ascensions of the same point in two systems: the two systems are the GCRS and the CIP,CIO, and the point is the ascending node of the CIP equator. The quantity  $s$  remains below  $0''.1$  throughout 1900-2100.
3. The series used to compute  $s$  is in fact for  $s + XY/2$ , where  $X$  and  $Y$  are the  $x$  and  $y$  components of the CIP unit vector; this series is more compact than a direct series for  $s$  would be. This routine requires  $X$  and  $Y$  to be supplied by the caller, who is responsible for providing values that are consistent with the supplied date.
4. The model is consistent with the "P03" precession (Capitaine et al. 2003), adopted by IAU 2006 Resolution 1, 2006, and the IAU 2000A nutation (with P03 adjustments).



**REFERENCES :**

1. Capitaine, N., Wallace, P.T. & Chapront, J., 2003, *Astron.Astrophys.* **432**, 355.
2. McCarthy, D.D., Petit, G. (eds.), 2004, *IERS Conventions (2003)*, IERS Technical Note No. 32, BKG.

---

**iau\_S06A** *CIO locator  $s$ , IAU 2006/2000A* **iau\_S06A**

**CALL :**

D = iau\_S06A ( DATE1, DATE2, X, Y )

**ACTION :**

The CIO locator  $s$ , positioning the Celestial Intermediate Origin on the equator of the Celestial Intermediate Pole, using the IAU 2006 precession and IAU 2000A nutation models.

**GIVEN :**

*DATE1*     d                    TT as a two-part...  
*DATE2*     d                    ... Julian Date (Note 1)

**RETURNED** (function value) :

d                    the CIO locator  $s$  in radians (Note 2)

**NOTES :**

1. The TT date DATE1+DATE2 is a Julian Date, apportioned in any convenient way between the arguments DATE1 and DATE2. For example, JD(TT) = 2450123.7 could be expressed in any of these ways, among others:

DATE1	DATE2	
2450123.7D0	0D0	(JD method)
2451545.0D0	-1421.3D0	(J2000 method)
2400000.5D0	50123.2D0	(MJD method)
2450123.5D0	0.2D0	(date & time method)

The JD method is the most natural and convenient to use in cases where the loss of several decimal digits of resolution is acceptable. The J2000 method is best matched to the way the argument is handled internally and will deliver the optimum resolution. The MJD method and the date & time methods are both good compromises between resolution and convenience.

2. The CIO locator  $s$  is the difference between the right ascensions of the same point in two systems: the two systems are the GCRS and the CIP,CIO, and the point is the ascending node of the CIP equator. The quantity  $s$  remains below 0".1 throughout 1900-2100.
3. The series used to compute  $s$  is in fact for  $s + XY/2$ , where  $X$  and  $Y$  are the  $x$  and  $y$  components of the CIP unit vector; this series is more compact than a direct series for  $s$  would be. The present routine uses the full IAU 2000A nutation model when predicting the CIP position.

**REFERENCES :**

1. Capitaine, N., Chapront, J., Lambert, S. & Wallace, P., 2003, *Astron.Astrophys.* **400**, 1145-1154.
2. Capitaine, N. & Wallace, P.T., 2006, *Astron.Astrophys.*, **450**, 855-872.
3. McCarthy, D.D., Petit, G. (eds.), 2004, *IERS Conventions (2003)*, IERS Technical Note No. 32, BKG.
4. Wallace, P.T. & Capitaine, N., 2006, *Astron.Astrophys.*, **459**, 981-985.

---

**iau\_SP00***TIO locator  $s'$* **iau\_SP00****CALL :**

D = iau\_SP00 ( DATE1, DATE2 )

**ACTION :**

The TIO locator  $s'$ , positioning the Terrestrial Intermediate Origin on the equator of the Celestial Intermediate Pole.

**GIVEN :**

<i>DATE1</i>	d	TT as a two-part...
<i>DATE2</i>	d	... Julian Date (Note 1)

**RETURNED** (function value) :

d	the TIO locator $s'$ in radians (Note 2)
---	--

**NOTES :**

1. The TT date DATE1+DATE2 is a Julian Date, apportioned in any convenient way between the arguments DATE1 and DATE2. For example,  $JD(TT) = 2450123.7$  could be expressed in any of these ways, among others:

DATE1	DATE2	
2450123.7D0	0D0	(JD method)
2451545.0D0	-1421.3D0	(J2000 method)
2400000.5D0	50123.2D0	(MJD method)
2450123.5D0	0.2D0	(date & time method)

The JD method is the most natural and convenient to use in cases where the loss of several decimal digits of resolution is acceptable. The J2000 method is best matched to the way the argument is handled internally and will deliver the optimum resolution. The MJD method and the date & time methods are both good compromises between resolution and convenience.

2. The TIO locator  $s'$  is obtained from polar motion observations by numerical integration, and so is in essence unpredictable. However, it is dominated by a secular drift of about  $47\mu\text{as}$  per century, which is the approximation evaluated by the present routine.

**REFERENCE :**

McCarthy, D.D., Petit, G. (eds.), 2004, IERS Conventions (2003), IERS Technical Note No. 32, BKG.

---

**iau\_TR** *transpose r-matrix* **iau\_TR**

**CALL :**

CALL iau\_TR ( R, RT )

**ACTION :**

Transpose an r-matrix.

**GIVEN :**

*R*            d(3,3)            r-matrix

**RETURNED :**

*RT*            d(3,3)            transpose

---

**iau\_XY06**     *CIP X,Y from series, IAU 2006/2000A compatible*     **iau\_XY06**

---

**CALL :**

CALL iau\_XY06 ( DATE1, DATE2, X, Y )

**ACTION :**

$X, Y$  coordinates of celestial intermediate pole from series based on IAU 2006 precession and IAU 2000A nutation.

**GIVEN :**

<i>DATE1</i>	d	TT as a two-part...
<i>DATE2</i>	d	... Julian Date (Note 1)

**RETURNED :**

$X, Y$	d	CIP $X, Y$ coordinates (Note 2)
--------	---	---------------------------------

**NOTES :**

1. The TT date  $DATE1+DATE2$  is a Julian Date, apportioned in any convenient way between the arguments  $DATE1$  and  $DATE2$ . For example,  $JD(TT) = 2450123.7$  could be expressed in any of these ways, among others:

DATE1	DATE2	
2450123.7D0	0D0	(JD method)
2451545.0D0	-1421.3D0	(J2000 method)
2400000.5D0	50123.2D0	(MJD method)
2450123.5D0	0.2D0	(date & time method)

The JD method is the most natural and convenient to use in cases where the loss of several decimal digits of resolution is acceptable. The J2000 method is best matched to the way the argument is handled internally and will deliver the optimum resolution. The MJD method and the date & time methods are both good compromises between resolution and convenience.

2. The  $X, Y$  coordinates are those of the unit vector towards the celestial intermediate pole. They represent the combined effects of frame bias, precession and nutation.
3. The fundamental arguments used are as adopted in IERS Conventions (2003) and are from Simon *et al.* (1994) and Souchay *et al.* (1999).
4. This is an alternative to the angles-based method, via the SOFA routine `iau_FW2XY` and as used in `iau_XYS06A` for example. The two methods agree at the  $1\mu\text{as}$  level (at present), a negligible amount compared with the intrinsic accuracy of the models. However, it would be unwise to mix the two methods (angles-based and series-based) in a single application.

**REFERENCES :**

1. Capitaine, N. & Wallace, P.T. & Chapront, J., 2003, *Astron.Astrophys.*, **412**, 567.
2. Capitaine, N. & Wallace, P.T., 2006, *Astron.Astrophys.*, **450**, 855-872.
3. McCarthy, D.D., Petit, G. (eds.), 2004, *IERS Conventions (2003)*, IERS Technical Note No. 32, BKG.
4. Simon, J.-L., Bretagnon, P., Chapront, J., Chapront-Touzé, M., Francou, G & Laskar J., 1994, *Astron.Astrophys.*, **282**, 663-683.
5. Souchay, J., Loysel, B., Kinoshita, H., Folgueira, M., 1999, *Astron.Astrophys.Supp.Ser.* **135**, 111.
6. Wallace, P.T. & Capitaine, N., 2006, *Astron.Astrophys.*, **459**, 981-985.

---

**iau\_XYS00A**      *CIP  $X, Y$  and CIO locator  $s$ , IAU 2000A*      **iau\_XYS00A**

---

**CALL :**

CALL iau\_XYS00A ( DATE1, DATE2, X, Y, S )

**ACTION :**

For a given TT date, compute the  $X, Y$  coordinates of the Celestial Intermediate Pole and the CIO locator  $s$ , using the IAU 2000A precession-nutation model.

**GIVEN :**

<i>DATE1</i>	d	TT as a two-part...
<i>DATE2</i>	d	... Julian Date (Note 1)

**RETURNED :**

$X, Y$	d	CIP $X, Y$ coordinates (Note 2)
$S$	d	the CIO locator $s$ (Note 3)

**NOTES :**

1. The TT date  $DATE1+DATE2$  is a Julian Date, apportioned in any convenient way between the arguments  $DATE1$  and  $DATE2$ . For example,  $JD(TT) = 2450123.7$  could be expressed in any of these ways, among others:

DATE1	DATE2	
2450123.7D0	0D0	(JD method)
2451545.0D0	-1421.3D0	(J2000 method)
2400000.5D0	50123.2D0	(MJD method)
2450123.5D0	0.2D0	(date & time method)

- The JD method is the most natural and convenient to use in cases where the loss of several decimal digits of resolution is acceptable. The J2000 method is best matched to the way the argument is handled internally and will deliver the optimum resolution. The MJD method and the date & time methods are both good compromises between resolution and convenience.
2. The  $X, Y$  coordinates are those of the unit vector towards the celestial intermediate pole. They represent the combined effects of frame bias, precession and nutation.
  3. The CIO locator  $s$  (in radians) positions the Celestial Intermediate Origin on the equator of the CIP.
  4. A faster, but slightly less accurate result (about 1 mas for  $X, Y$ ), can be obtained by using instead the `iau_XYS00B` routine.

**REFERENCE :**

McCarthy, D.D., Petit, G. (eds.), 2004, IERS Conventions (2003), IERS Technical Note No. 32, BKG.

---

**iau\_XYS00B**      *CIP  $X, Y$  and CIO locator  $s$ , IAU 2000B*      **iau\_XYS00B**

**CALL :**

CALL iau\_XYS00B ( DATE1, DATE2, X, Y, S )

**ACTION :**

For a given TT date, compute the  $X, Y$  coordinates of the Celestial Intermediate Pole and the CIO locator  $s$ , using the IAU 2000B precession-nutation model.

**GIVEN :**

<i>DATE1</i>	d	TT as a two-part...
<i>DATE2</i>	d	... Julian Date (Note 1)

**RETURNED :**

$X, Y$	d	CIP $X, Y$ coordinates (Note 2)
$S$	d	the CIO locator $s$ (Note 3)

**NOTES :**

1. The TT date  $DATE1+DATE2$  is a Julian Date, apportioned in any convenient way between the arguments  $DATE1$  and  $DATE2$ . For example,  $JD(TT) = 2450123.7$  could be expressed in any of these ways, among others:

DATE1	DATE2	
2450123.7D0	0D0	(JD method)
2451545.0D0	-1421.3D0	(J2000 method)
2400000.5D0	50123.2D0	(MJD method)
2450123.5D0	0.2D0	(date & time method)

The JD method is the most natural and convenient to use in cases where the loss of several decimal digits of resolution is acceptable. The J2000 method is best matched to the way the argument is handled internally and will deliver the optimum resolution. The MJD method and the date & time methods are both good compromises between resolution and convenience.

2. The  $X, Y$  coordinates are those of the unit vector towards the celestial intermediate pole. They represent the combined effects of frame bias, precession and nutation.
3. The CIO locator  $s$  (in radians) positions the Celestial Intermediate Origin on the equator of the CIP.
4. The present routine is faster, but slightly less accurate (about 1 mas in  $X, Y$ ), than the iau\_XYS00A routine.

**REFERENCE :**

McCarthy, D.D., Petit, G. (eds.), 2004, IERS Conventions (2003), IERS Technical Note No. 32, BKG.



---

**iau\_XYS06A** *CIP  $X, Y$  and CIO locator  $s$ , IAU 2006/2000A* **iau\_XYS06A**
**CALL :**

CALL iau\_XYS06A ( DATE1, DATE2, X, Y, S )

**ACTION :**

For a given TT date, compute the  $X, Y$  coordinates of the Celestial Intermediate Pole and the CIO locator  $s$ , using the IAU 2006 precession and IAU 2000A nutation models.

**GIVEN :**

<i>DATE1</i>	d	TT as a two-part...
<i>DATE2</i>	d	... Julian Date (Note 1)

**RETURNED :**

$X, Y$	d	CIP $X, Y$ coordinates (Note 2)
$S$	d	the CIO locator $s$ (Note 3)

**NOTES :**

1. The TT date  $DATE1+DATE2$  is a Julian Date, apportioned in any convenient way between the arguments  $DATE1$  and  $DATE2$ . For example,  $JD(TT) = 2450123.7$  could be expressed in any of these ways, among others:

DATE1	DATE2	
2450123.7D0	0D0	(JD method)
2451545.0D0	-1421.3D0	(J2000 method)
2400000.5D0	50123.2D0	(MJD method)
2450123.5D0	0.2D0	(date & time method)

The JD method is the most natural and convenient to use in cases where the loss of several decimal digits of resolution is acceptable. The J2000 method is best matched to the way the argument is handled internally and will deliver the optimum resolution. The MJD method and the date & time methods are both good compromises between resolution and convenience.

2. The  $X, Y$  coordinates are those of the unit vector towards the celestial intermediate pole. They represent the combined effects of frame bias, precession and nutation.
3. The CIO locator  $s$  (in radians) positions the Celestial Intermediate Origin on the equator of the CIP.
4. Series-based solutions for generating  $X, Y$  are also available: see Capitaine & Wallace (2006) and iau\_XY06.

**REFERENCES :**

1. Capitaine, N. & Wallace, P.T., 2006, *Astron.Astrophys.*, **450**, 855-872.
2. Wallace, P.T. & Capitaine, N., 2006, *Astron.Astrophys.*, **459**, 981-985.

## 8 APPENDIX

### Interrelationships between IAU 2006/2000A SOFA Fortran routines

The three diagrams set out SOFA's IAU 2006/2000A procedures and the principal routines that each calls; a few frequently-used utility routines, such as `iau_BPN2XY` and `iau_FW2M`, are omitted in most cases in order to avoid over-complicating the diagram.

The first line of each box gives the name of the Fortran routine. Those routines classed as "canonical" have their names printed in red. Routines that are FUNCTION (as opposed to SUBROUTINE) subprograms are indicated by an equals sign at the start of the third line, that precedes the quantity being returned. The second line lists the input (given) arguments (green), where all dates are given as either TT or UT (*i.e.* UT1); however, all routines use two-argument Julian dates and fraction, either TT or UT1, as indicated. The third and following lines list the output (returned) arguments. All angular quantities are expressed in radians. Usual mathematical symbols have been used to denote the quantities, with matrices given in bold.

#### Line Comment

1. Routine name: **red** implies canonical procedure.
2. Input arguments **green**, separated by commas. Note; all TT and UT (*i.e.* UT1) arguments occupy two arguments.
3. Output arguments, separated by commas. In the case of FUNCTION subprograms, the value returned is preceded by an equals (=) sign.

#### Quantities returned by canonical routines

1. Precession angles  $\gamma$ ,  $\varphi$ ,  $\psi$ , which include frame bias.
2. Bias, precession, and bias-precession matrices, **B**, **P**, **PB**.
3. Mean obliquity of date,  $\varepsilon_A$ .
4. Nutation in longitude and obliquity,  $\Delta\psi$ ,  $\Delta\varepsilon$ .
5. Earth rotation angle,  $\theta$ .
6. Greenwich mean sidereal time, GMST.
7. Locators for the CIO ( $s$ ) and TIO ( $s'$ ).
8. Series evaluations for  $(X, Y)$  coordinates of the CIP.
9. Fundamental arguments,  $l$ ,  $l'$ ,  $F$ ,  $D$ ,  $\Omega$ ,  $\lambda_{Me}$ ,  $\lambda_V$ ,  $\lambda_E$ ,  $\lambda_{Ma}$ ,  $\lambda_{Ju}$ ,  $\lambda_{Sa}$ ,  $\lambda_{Ur}$ ,  $\lambda_{Ne}$ , and  $p_A$  from IERS Conventions 2003. None of these routines appear in the charts.
10. Equinox based precession angles;  $\varepsilon_0$ ,  $\psi_A$ ,  $\omega_A$ ,  $P_A$ ,  $Q_A$ ,  $\pi_A$ ,  $\Pi_A$ ,  $\chi_A$ ,  $z_A$ ,  $\zeta_A$ ,  $\theta_A$ ,  $p_A$ ,  $\eta$ ,  $\varphi$ ,  $\psi$ . Angles are relative to the J2000.0 dynamical system and thus are without frame bias.

#### Other quantities returned

11.  $(X, Y)$  of the CIP is calculated using bias, precession and nutation angles, SOFA's chosen method, with the sole exception of `iau_XY06`.
12. Nutation matrix **N**.
13. GCRS to equinox and equator of date; bias, precession and nutation matrix **NPB**.
14. GCRS to Celestial Intermediate Reference System: matrix **C**.
15. Polar motion matrix, including  $s'$  **W**.
16. GCRS to ITRS matrix **Q**<sup>-1</sup>.
17. Greenwich apparent sidereal time, GAST.
18. Equation of the equinoxes, EE.
19. Equation of the origins, EO.
20. Equinox precession angles,  $\zeta_B$ ,  $z_B$ ,  $\theta_B$ , including frame bias.

## IAU 2006/2000A SOFA FORTRAN ROUTINES

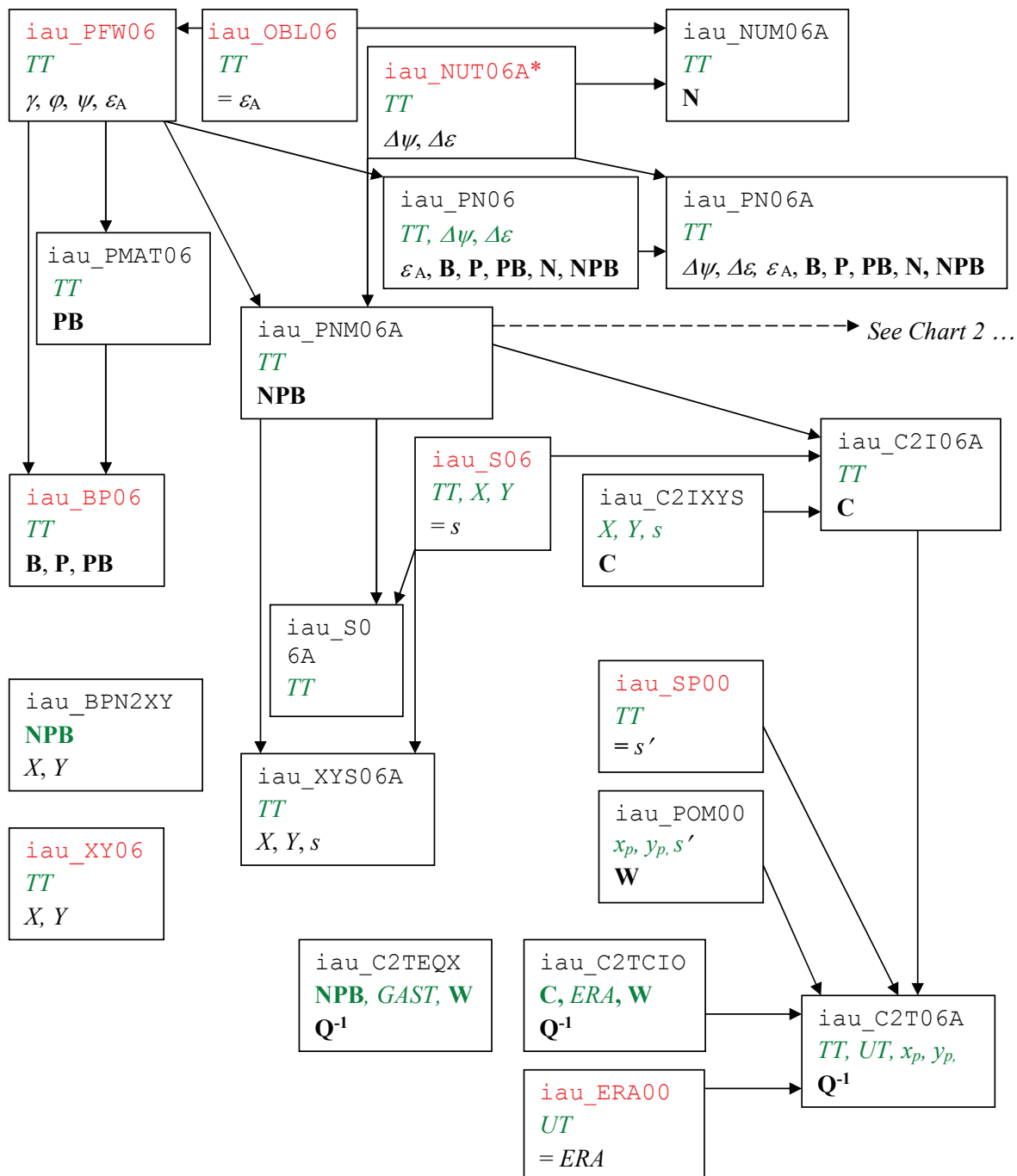
**Chart 1:** The main routines for transforming from the GCRS to CIRS, TIRS and ITRS.

\* Note: `iau_NUT06A` calls `iau_NUT00A`.

### IAU 2006/2000A SOFA FORTRAN ROUTINES

**Chart 2:** Equinox based routines for calculating GAST and related quantities.

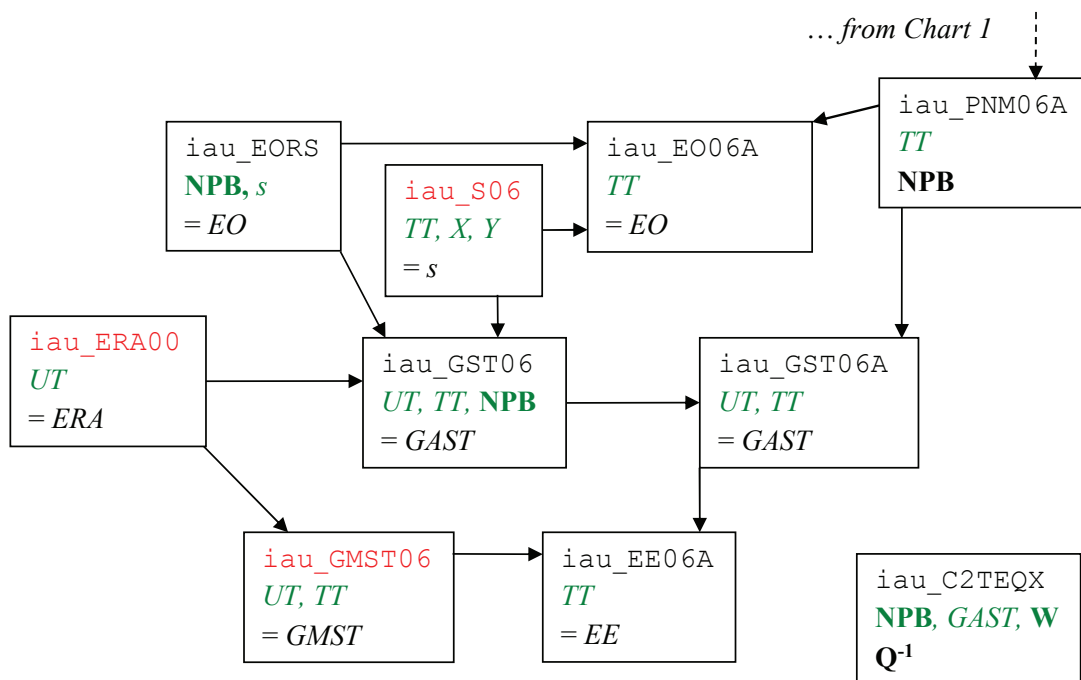

**Chart 3:** Routines for bias, precession and nutation; not all are shown in Chart 1.

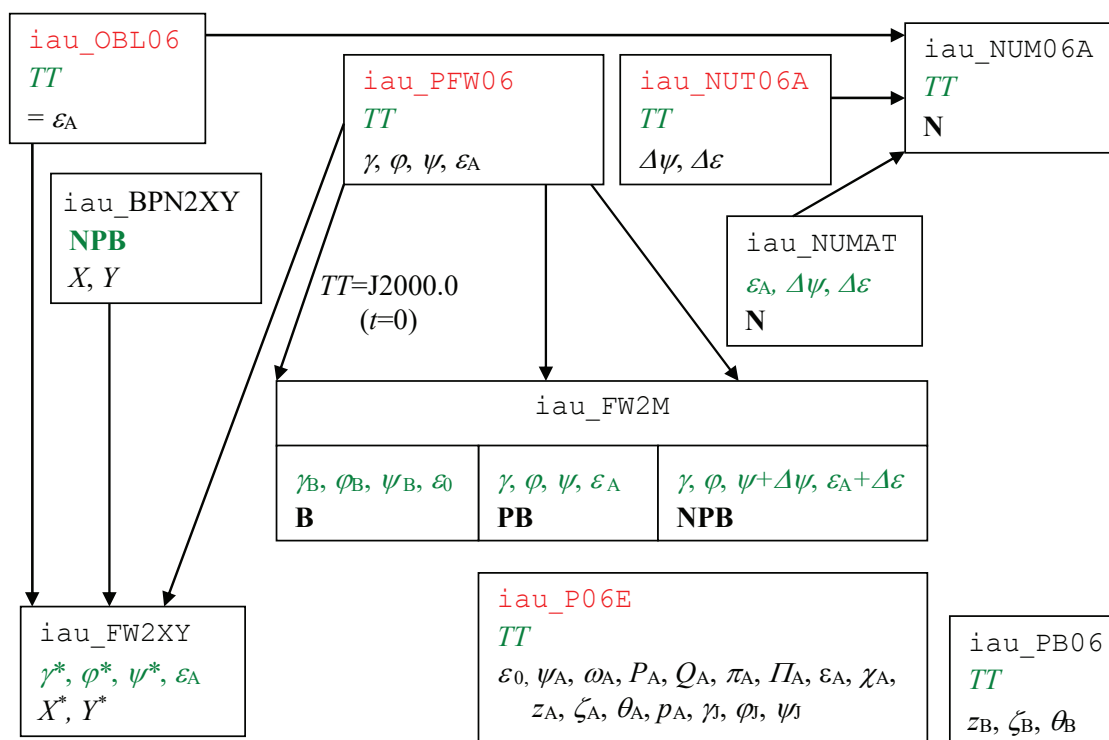

\* The arguments supplied by the user may be any of the three sets given for iau\_FW2M.

## IAU 2006/2000A SOFA FORTRAN ROUTINES

### NOTES

#### Equinox based

$$[\text{ITRS}] = \mathbf{W} \mathbf{R}_3(\text{GAST}) \mathbf{NPB} [\text{GCRS}]$$

#### CIO based

$$\begin{aligned} [\text{ITRS}] &= \mathbf{W} \mathbf{R}_3(\theta) \mathbf{C} [\text{GCRS}] \\ &= \mathbf{Q}^{-1} [\text{GCRS}] \end{aligned}$$

Symbol	Quantity	Rotation from / to	
<b>Equinox based</b>			
<b>B</b>	Bias	ICRS to mean equator and equinox of J2000.0.	GCRS → J2000
<b>P</b>	Precession	J2000.0 to mean equator and equinox of date.	J2000 → mean of date
<b>N</b>	Nutation	Mean equator of date to true equator and equinox of date.	mean of date → true of date (EES)
<b>R<sub>3</sub>(GAST)</b>	Greenwich apparent sidereal time	True equator and equinox of date to the Terrestrial Intermediate Reference System.	EES (true of date) → TIRS
<b>NPB</b>			GCRS → true of date
<b>CIO based</b>			
<b>C</b>	Bias, precession-nutation	GCRS to Celestial Intermediate Reference System (true equator of date).	GCRS → CIRS
<b>R<sub>3</sub>(θ)</b>	Earth rotation angle	CIRS to the Terrestrial Intermediate Reference System.	CIRS → TIRS
<b>Q<sup>-1</sup></b> <b>Q</b>		GCRS to the International Terrestrial Reference System.	GCRS → ITRS ITRS → GCRS
<b>Terrestrial</b>			
<b>W</b>	Polar motion	TIRS to the International Terrestrial Reference System; includes R <sub>3</sub> (s').	TIRS → ITRS